



Digitale Fotografie für das Web MEINF4330

Grundlagen der Fotografie II mehr Physik

16.11.2023

Version 1.0

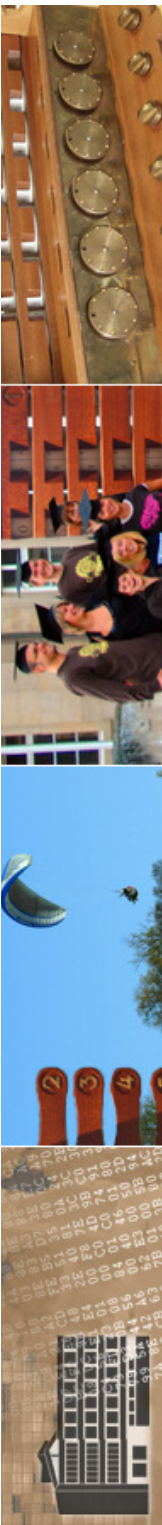



der “rote Faden“

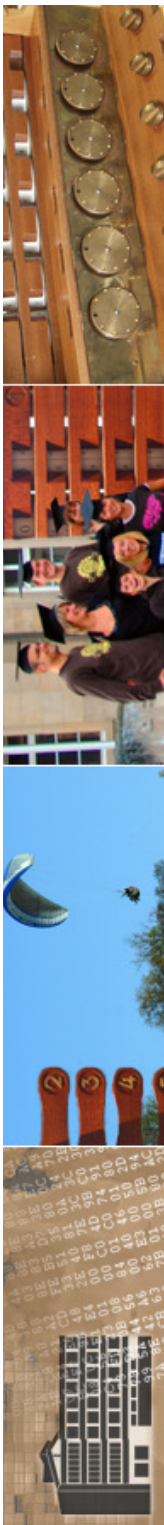



AFFINITY

PHOTO

DESIGNER

PUBLISHER

STORE

LERNEN



MENÜ



AFFINITY
Photo

30 % RABATT

ÜBERSICHT

IPAD

TECHNISCHE DATEN

JETZT KAUFEN





Unternehmen

PRESSERAUM

PRESSEMATERIAL

INFO

KONTAKT

PRESEMITTEILUNG

9. November 2022

Affinity 2 setzt einen neuen Standard für Kreativsoftware.

Brandneue Produkte erscheinen noch heute, Affinity V2-Universallizenz angekündigt und Affinity Publisher kommt für das iPad.





Sony Alpha 9 III

- 07.11.2023: erste Kamera mit Global Shutter: Zeitgleiches Auslesen des gesamten Sensors: **Sony Alpha 9 III**

– 24 MP

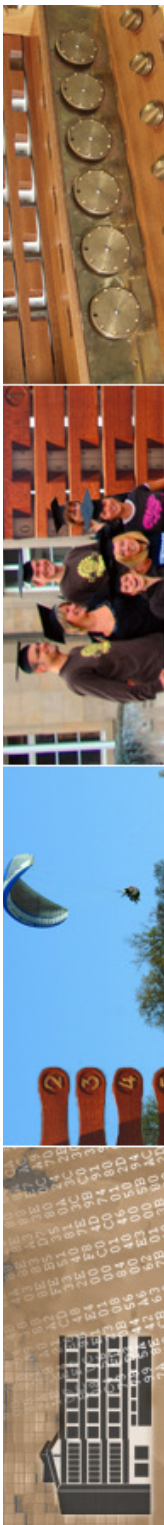



$\alpha 9$ III

24.6MP

Global shutter system

Blackout-free

120 fps with AF/AE tracking

AI processing unit

Exmor RS BIONZ XR
CMOS Sensor

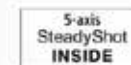



Global Shutter

- mechanischer Verschluss: 3ms
- Nikon Z8/Z9 (stacked sensor): 4,5 MS
- CANON R3 (Stacked sensor): 5 ms
- normaler BSI Sensor: 20ms - 60ms
- global shutter: 0ms

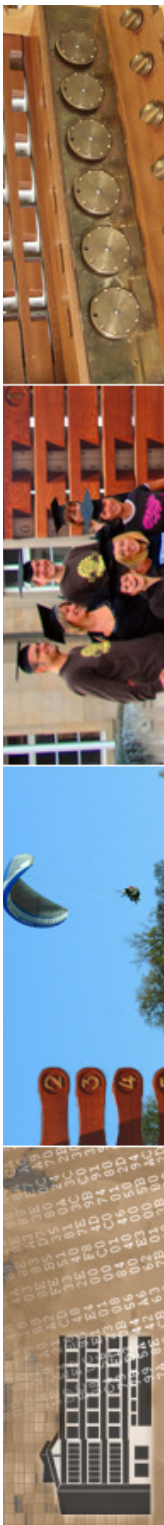

unser Gast

- Ingo Cordes in einer Vorlesung im Januar 2024

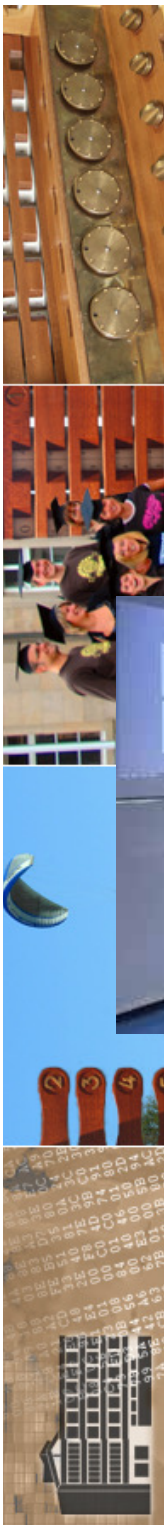

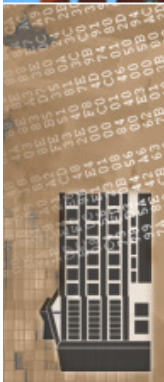
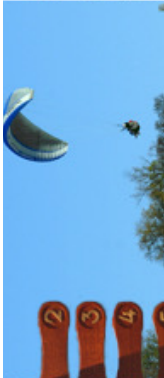



Abbildungsfehler

- zahlreiche Abbildungsfehler
 - chromatische Aberration
 - Distorsion
 - sphärische Aberration
 - Vignettierung
 - Oberflächenreflexion

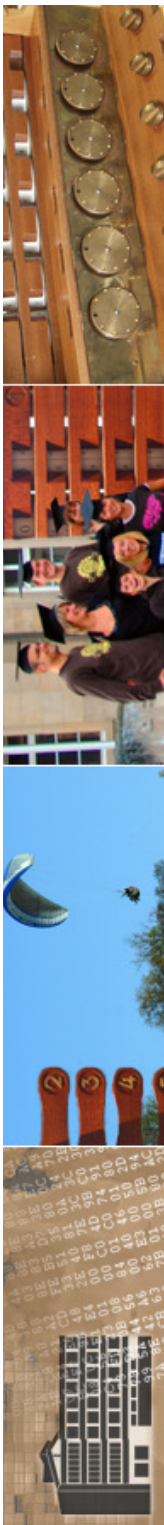

chromatische Aberration

- Glas bricht rotes Licht (Licht mit der größten Wellenlänge) am schwächsten, violettes Licht (Licht mit der kleinsten Wellenlänge) am stärksten.

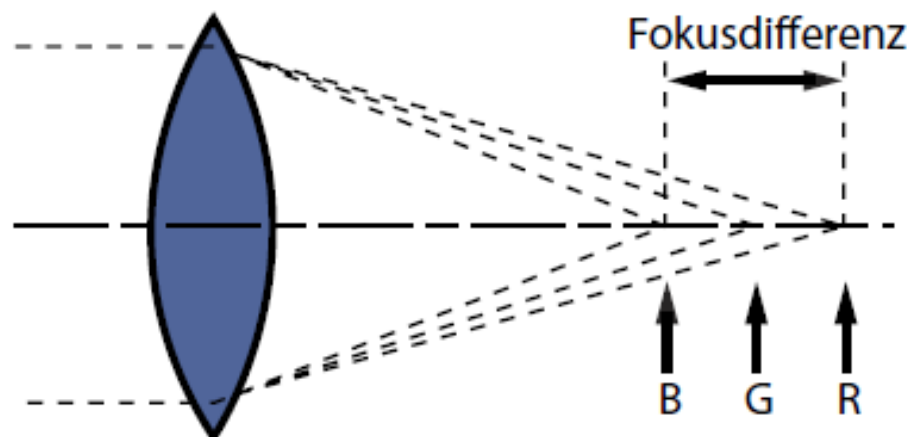



Farblängsfehler bei Offenblende: purpurne Farbränder vor der Fokusebene, grüne dahinter

 Weitere Einzel



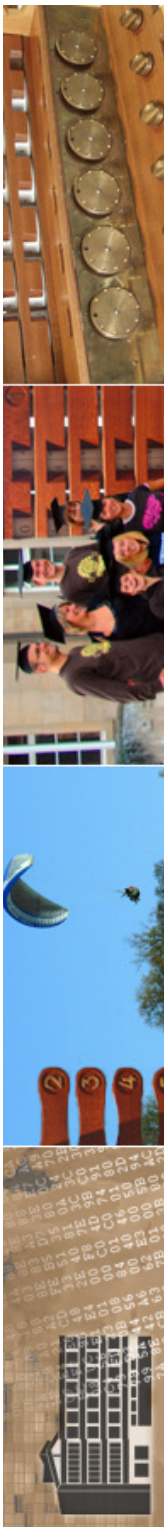

© 2023 Universität
Tübingen



achromatische Linsen

- Abblenden: Reduzierung der CA
- achromatische Linsen

| Glassorte | Rot | Gelb | Blau-Grün | Violett |
|-----------------|-------|-------|-----------|---------|
| Kronglas (BK 1) | 1,526 | 1,530 | 1,536 | 1,547 |
| Flintglas (F3) | 1,628 | 1,635 | 1,648 | 1,671 |

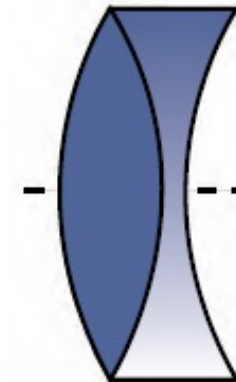

- ...vom Kronglas stammt der Name „Summicron“



Abbe-Zahl v

- wesentliche Beschreibung von Glas
 - D-Linie (He): $\lambda=587,56\text{nm}$
 - F-Linie (H): $\lambda=486,13\text{nm}$
 - C-Linie (H): $\lambda=656,27\text{nm}$



$$v_d = \frac{n_d - 1}{n_F - n_C}$$

- $v > 50$: Kronglas, $v < 50$ Flintglas

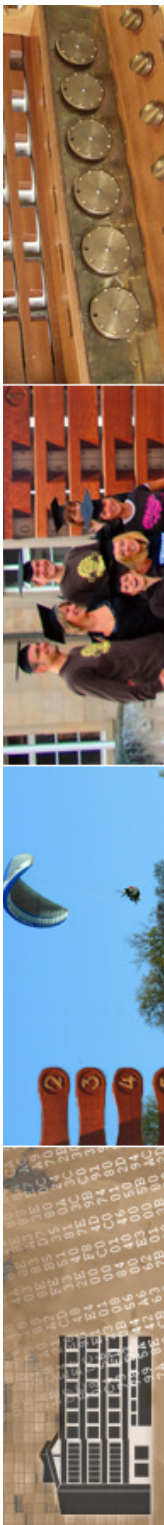

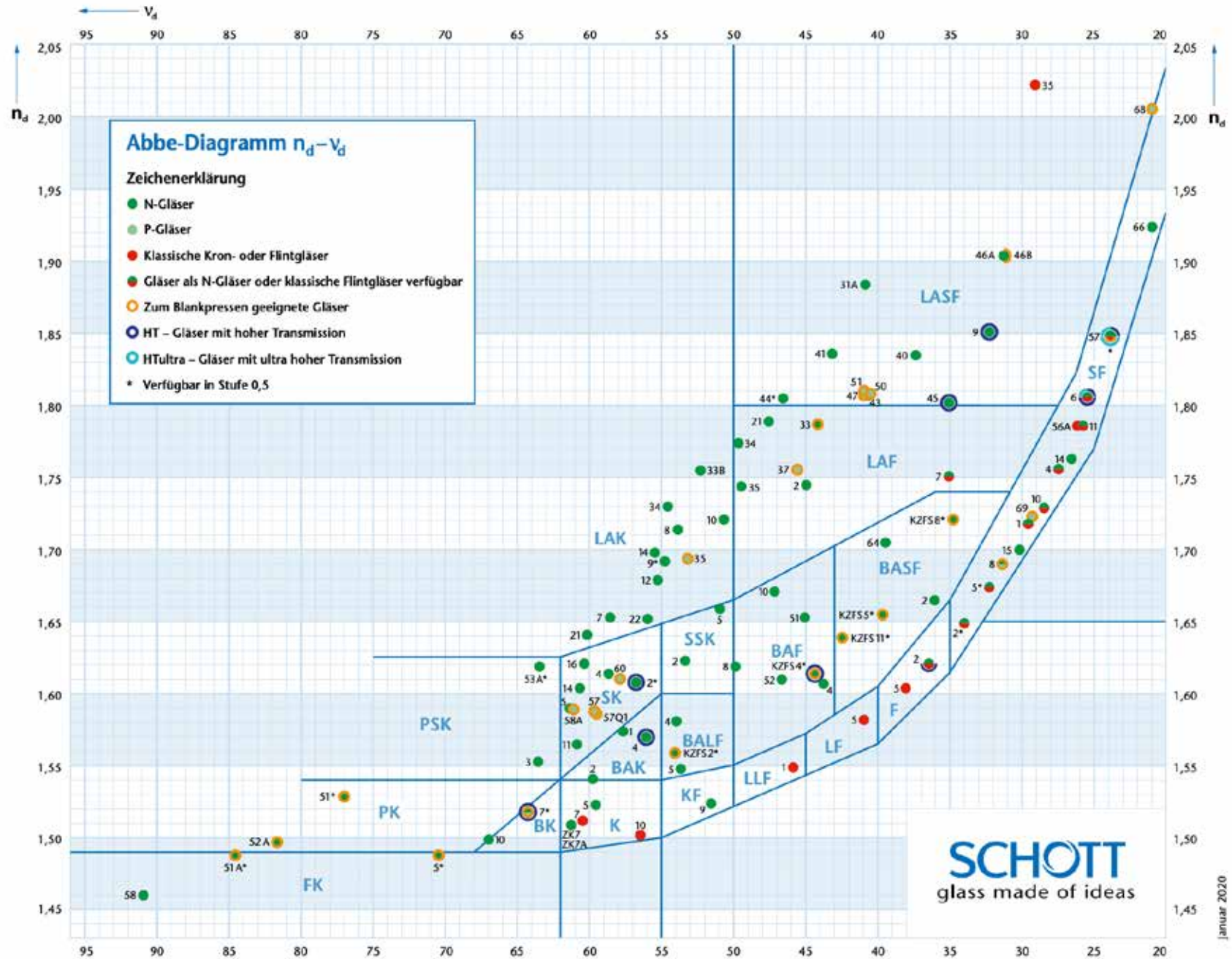

SCHOTT
glass made of ideas

Januar 2020

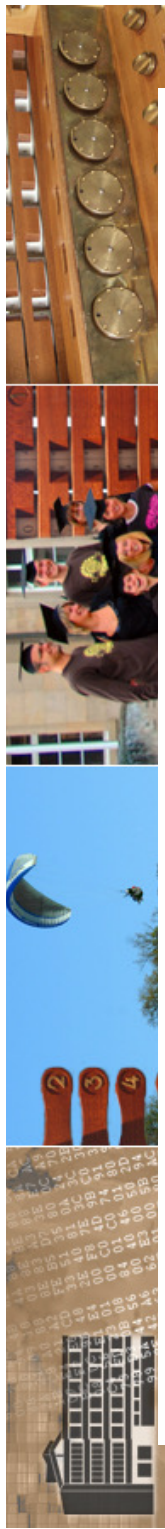



Schott

- 1884: Gründung in Jena durch Otto Schott, Ernst Abbe und Roderich Zeiss
- 1952 Neuaufbau in Mainz
- vollständiger Eigentum der Carl Zeiss Stiftung

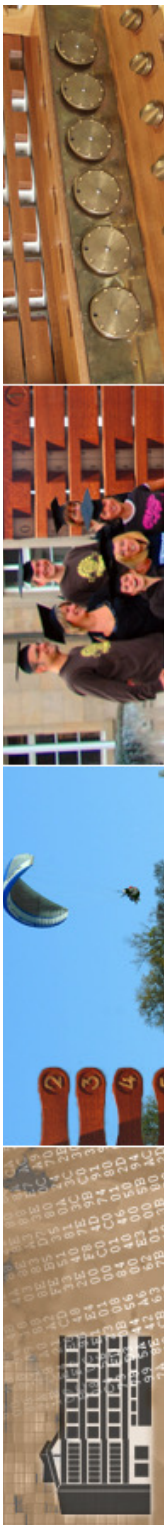



 Corporate (deutsch) ändern
Visitors from North America, please click here...

follow SCHOTT | Kontakt

[Innovation](#) [Produkte](#) [Presse](#) [Karriere](#) [Über SCHOTT](#)



Ein Material mit dem gewissen Etwas

Die Eigenschaften von Spezialglas sind so bunt und vielfältig, wie seine Einsatzmöglichkeiten. Ein Material, das uns oft zum Staunen bringt und bestehende Denkweisen immer wieder aufs Neue herausfordert. Gleichzeitig gibt Spezialglas Antwort auf viele Fragen und ermöglicht spannende Anwendungen in nahezu allen Lebensbereichen. Entdecken Sie das



110 Millionen täglich

Impfstoffe sind eines der Top-Themen dieser Tage. Bei Arzneimitteln ist es extrem wichtig, dass sie geschützt in hochwertigen Behältern aufbewahrt werden. Das einst vom Glaspionier Otto Schott erfundene Borosilicatglas wird weltweit von unterschiedlichen Glasunternehmen produziert und ist der Goldstandard für die Verpackung von Medikamenten. Täglich werden etwa 110 Millionen Injektionen aus solchen Borosilicatglasbehältern ver-

© 2

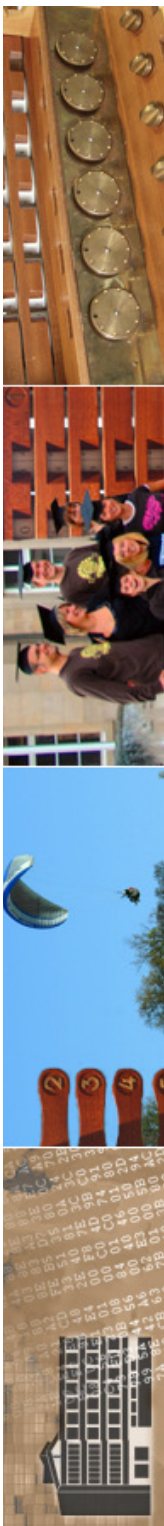

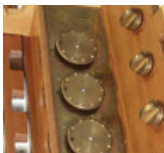

Aktuelles

Die Chemie stimmt

Säuren und Laugen lassen die meisten Stoffe in Rauch aufgehen. Nicht so Spezialglas: Sogar nach sechs Stunden in kochender Salzsäure ist es praktisch unversehrt. Das macht es zu einem unverzichtbaren Material für chemische Anwendungen mit besonders reaktionsfreudigen Stoffen.

Solutions

Starcatcher

Die neue Ausgabe des Technologiema­gazines „solutions“ wirft Blicke ins All – und auf die Erde.





[HOME](#)

[ÜBER SCHOTT](#)

[PRODUKTE & ANWENDUNGEN](#)

[WELTWEIT](#)

[PRESSE](#)

[KARRIERE](#)

Gemeinsam denken wir Glas neu.

Durch unsere kontinuierliche Weiterentwicklung des Materials Glas – seit nunmehr über 130 Jahren – ermöglichen wir unseren Kunden, Produkte zu entwickeln, die bestehende Möglichkeiten übertreffen und Märkte verändern.

Klicken Sie hier um mehr zu erfahren!

Unsere Produkte im Überblick

[Willkommen bei SCHOTT](#)

[SCHOTT entdecken](#)

[See more](#)

[Technology Magazine](#)

[Student Challenge](#)



Spezialglas hilft beim Aufspüren von Neutrinos

Im Sudbury Neutrino Observatory (SNO) sind Glaskolben von SCHOTT wertvolle Helfer: Fast 10.000 dieser Komponenten mit hervorragenden optischen Eigenschaften sorgen in einer riesigen mit schwerem Wasser gefüllten Kunststoffkugel für den

Schutz extrem empfindlicher Detektoren. Diese fangen Lichtblitze von Neutrinos ein, wandeln sie in elektrische Signale um und verstärken sie. Die erhaltenen Daten haben das Verständnis von Materie und Universum



Per Fingertipp schalten

Glas in Hausgeräten bietet nicht nur ein edles Design, sondern ermöglicht auch vielfältige Funktionen. In seinen Einbaugeräten mit weißen oder schwarzen Glasfronten verwendet Bosch z.B. moderne Touch-Technologie mit dem taktilen Feedback eines mechanischen Bedienrings. Um diese in einer

Glasblende zu integrieren, ist eine hochpräzise und sehr anspruchsvolle Glasbearbeitung erforderlich, für die SCHOTT verantwortlich zeichnet. Besonders Eigenschaften machen Glas zum idealen Werkstoff für Touch



Optisches Glas

Im Folgenden finden Sie einen Überblick über die Produktgruppe 'Optisches Glas', unterschiedlich dargestellt: nach Produkten, nach Produkten von A-Z sowie nach verfügbaren Lieferformen. Durch Klick auf das jeweilige Produktbild gelangen Sie auf die entsprechende Produktseite.

[Produkte](#) | [Produkte A-Z](#) | [Lieferformen](#)

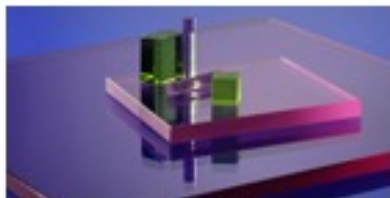

Aktive & Passive
Lasergläser



Hochhomogene Gläser



HT & HTultra-Gläser



i-Linienglas



Low Tg-Gläser



Optisches Glas



Strahlenresistentes
Glas



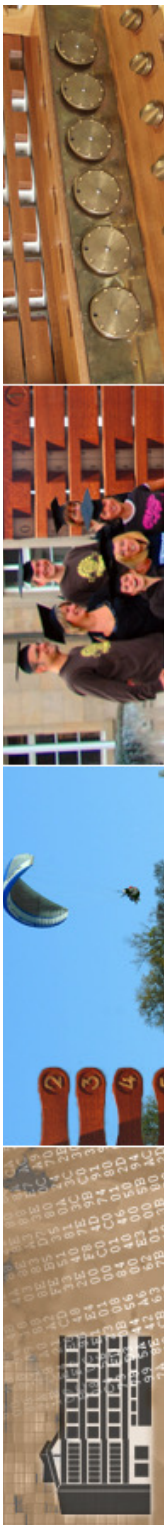

SCHOTT
glass made of Ideas

Corporate (deutsch) [ändern](#)
Visitors from North America, please click here...

follow SCHOTT | Kontakt

Innovation
Produkte
Presse
Karriere
Über SCHOTT

| | | | |
|-----------------------------|-------------------------|----------------------|------------------|
| Architektur > | ANWENDUNGEN | | |
| Automobil > | Exterior > | Glas für Museen > | Interior > |
| Energie & Umwelt > | Kunst und Design > | Strahlenschutzglas > | |
| Industrieausrüstung > | MARKEN | | |
| Kommerzielle Kühlung > | AMIRAN® | BOROFLOAT® | CONTURAN® |
| Life Sciences > | CONTURAX® Pro | DURAN® | GOETHEGLAS |
| Living > | MIROGARD Protect® Ultra | MIROGARD® | MIROGARD® DARO |
| Luftfahrt > | MIRONA® | NARIMA® | NEXTREMA® |
| Medizintechnik > | NOVOLAY® secure | PYRANOVA® | PYRANOVA® secure |
| Optik > | PYRAN® | RD 30® | RD 50® |
| Pharma > | RESTOVER® | RIVULETTA® | TIKANA® |
| Semiconductor & Datacom > | | | |
| Unterhaltungselektronik > | | | |
| Verteidigung & Sicherheit > | | | |





Optisches Glas



[Produktinformation](#) | [Vorteile](#) | [Anwendungen](#) | [Lieferformen](#) | [Technische Details](#) | [Downloads](#) | [Kontakte](#)

MEHR ALS 120 OPTISCHE GLASTYPEN

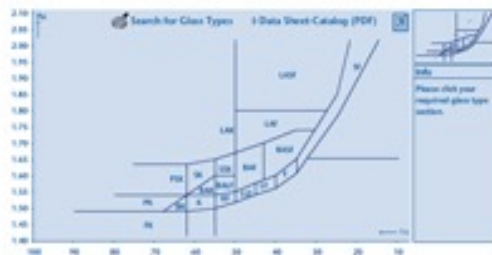

Unser derzeitig verfügbares Portfolio an optischen Gläsern wird im Abbe-Diagramm, als einem unserer wichtigsten optischen Glas-Tools, abgebildet.

Hier gelangen Sie zu einem [interaktiven Abbe-Diagramm](#), welches einen Überblick über all unsere optischen Glastypeen gibt. Bitte klicken Sie auf das Symbol links, um detaillierte Informationen zu den Eigenschaften zu erhalten oder Datenblätter herunterzuladen.

Seit über 125 Jahren fertigt SCHOTT Advanced Optics ein breites Sortiment hochwertiger optischer Gläser, um die Anforderungen einer Vielzahl optischer und industrieller Anwendungen zu erfüllen – vom Konsumgüterbereich bis hin zu innovativen optischen Systemen in Forschung und Entwicklung.



Interaktives Abbe-Diagramm

Abbe-Diagramm | Suche nach Glastypeen

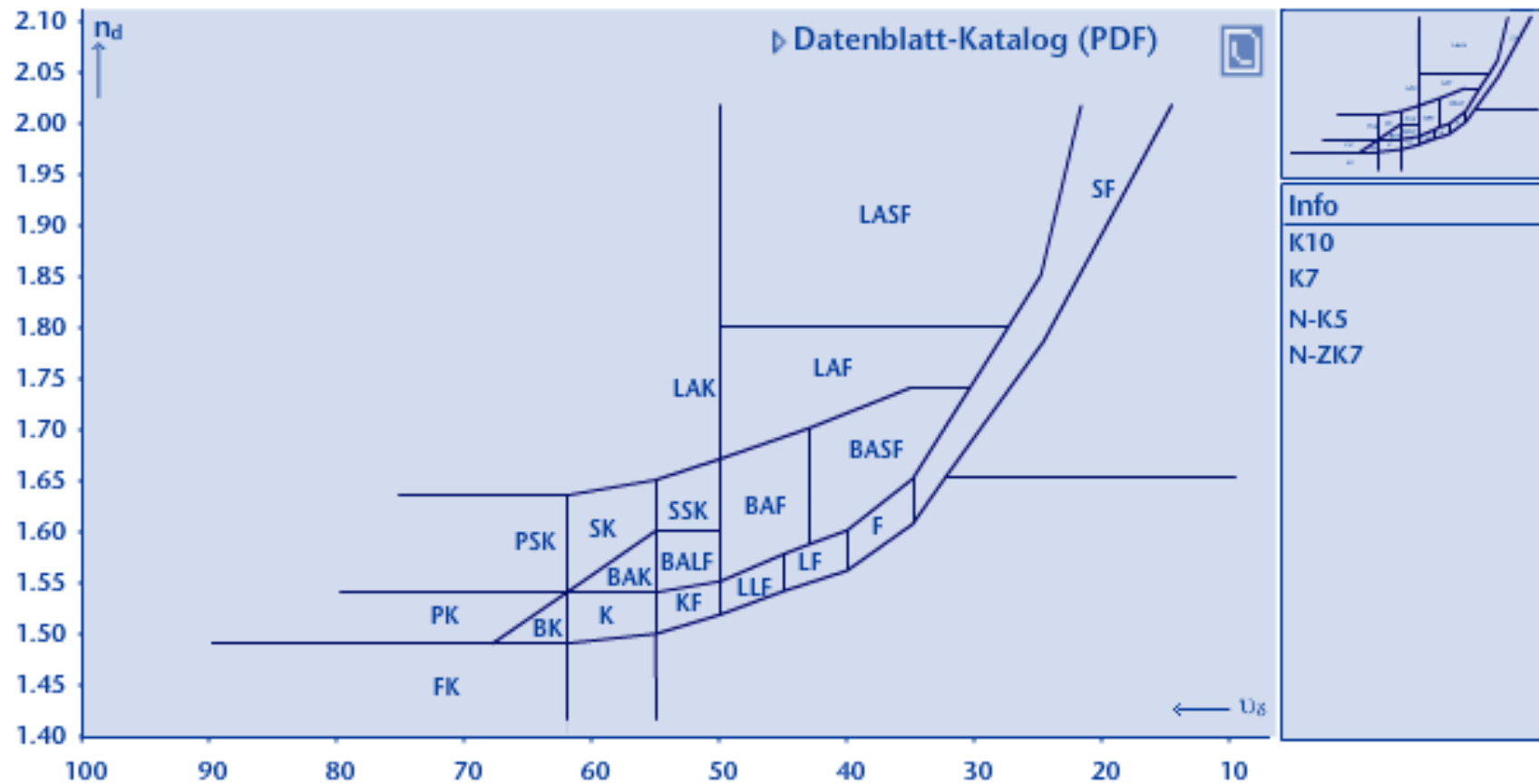



Literatur

- https://www.schott.com/d/advanced_optics/47d79895-2965-472d-83ed-af9e48ac72c0/1.15/schott-optisches-glas-datenblatt-sammlung-german-may-2019.pdf
- <http://www.schott.com/shop/medias/schott-optical-glass-pocket-catalog-2020-de.pdf>

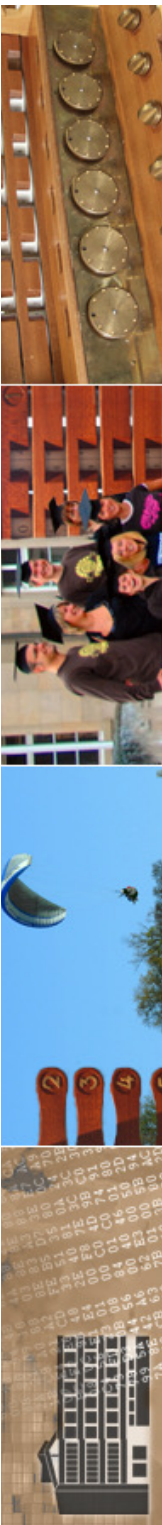



Corning Glass

- das „amerikanische Schott“: Corning
 - 1851 gegründet
 - ca. 26.000 Mitarbeiter
 - u.a. Gorilla Glass (iPhone)

CORNING

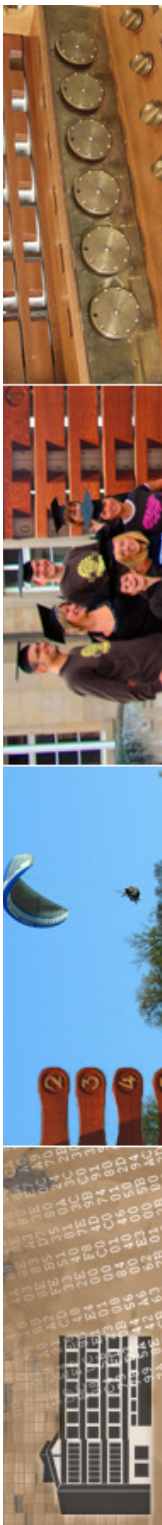



Innovation als Grundlage des Unternehmenswachstums

„Bei Corning entwickeln wir ständig neue Innovationen, die das Leben der Menschen bereichern und Branchen verändern.“ — Wendell P. Weeks, Vorsitzender und Geschäftsführer. Besuchen Sie unsere vollständige Investor Relations-Website in englischer Sprache.

Weitere Informationen



Seit mehr als 165 Jahren nutzt Corning sein Fachwissen in den Bereichen Glaswissenschaft, Keramik-Wissenschaft und optische Physik, um lebensverändernde Innovationen und Produkte zu entwickeln, die aus dem täglichen Leben nicht mehr wegzudenken sind.



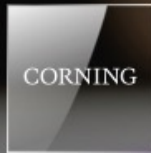

Produkte

Branchen

Innovation

Über uns



Sie werden Corning nie wieder auf die selbe Weise betrachten

Willkommen zum komplett neuen Internetauftritt von Corning.com! Hier finden Sie erstklassige Suchoptionen, einfache Navigationswerkzeuge sowie mannigfaltige Wege, um unser Unternehmen, unsere Kultur sowie unsere Produkte und Services kennenzulernen.

Jetzt ansehen



Seit mehr als 160 Jahren entwickelt Corning Produkte und Verfahren, die neue Branchen begründen und das Leben der Menschen bereichern - dank seines beispiellosen Fachwissens über Spezialglas, Keramik und optische Physik.

Willkommen im "Glaserzeitalter"

Tübingen

Web Wintersemester 2023/2024



20

Sondergläser

- Glas mit anormaler Teildispersion
- Fluoritglas
 - auch die Temperatureigenschaften sind wesentlich

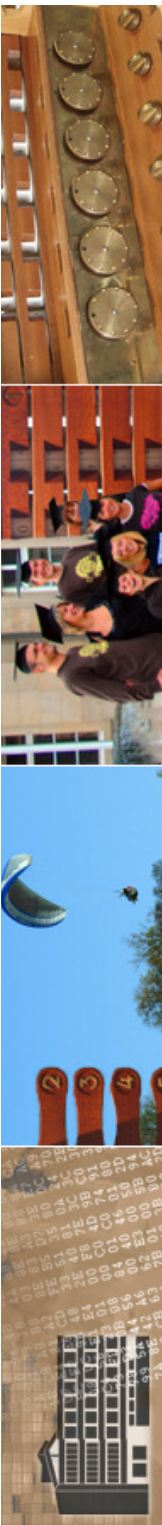



PS-Raw-Konverter

- Korrektur der CA in PS

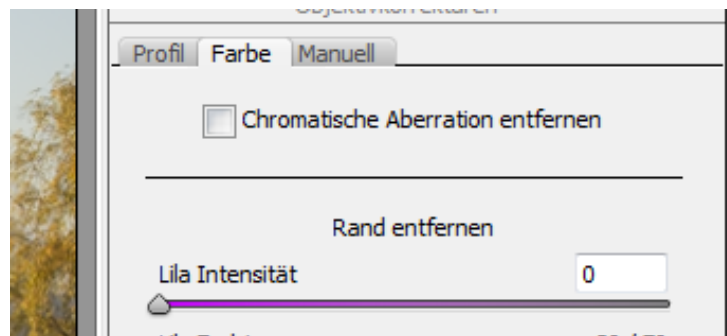



Lightroom

- Korrektur der CA in Adobe Lightroom

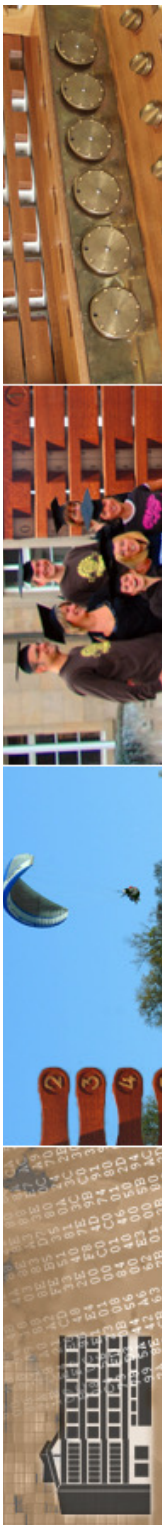
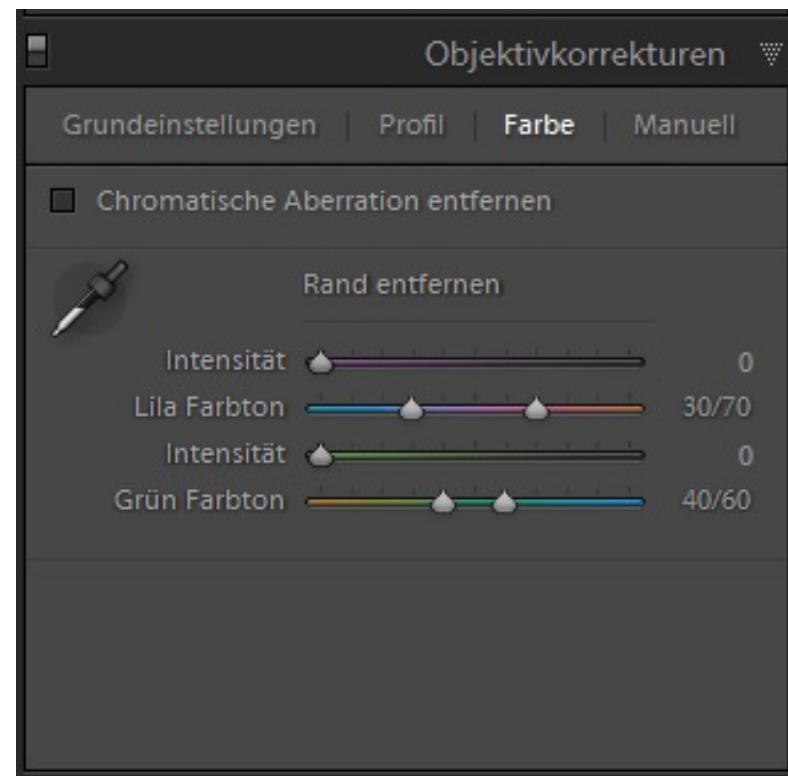



Neuere Entwicklungen

- <https://www.seas.harvard.edu/news/2018/11/meta-surface-corrects-for-chromatic-aberrations-across-all-kinds-of-lenses?nr=nr>

HARVARD
John A. Paulson
School of Engineering
and Applied Sciences

ABOUT SEAS ACADEMICS FACULTY & RESEARCH NEWS

News & Events
Calendars & Colloquia
For the Media
SEAS Videos

> News & Events > Meta-surface corrects for chromatic aberrations across all kinds of lenses

Meta-surface corrects for chromatic aberrations across all kinds of lenses

The single-layer surface of nanostructures can be incorporated into commercial optical systems, from simple to complex

By Leah Burrows | November 19, 2018

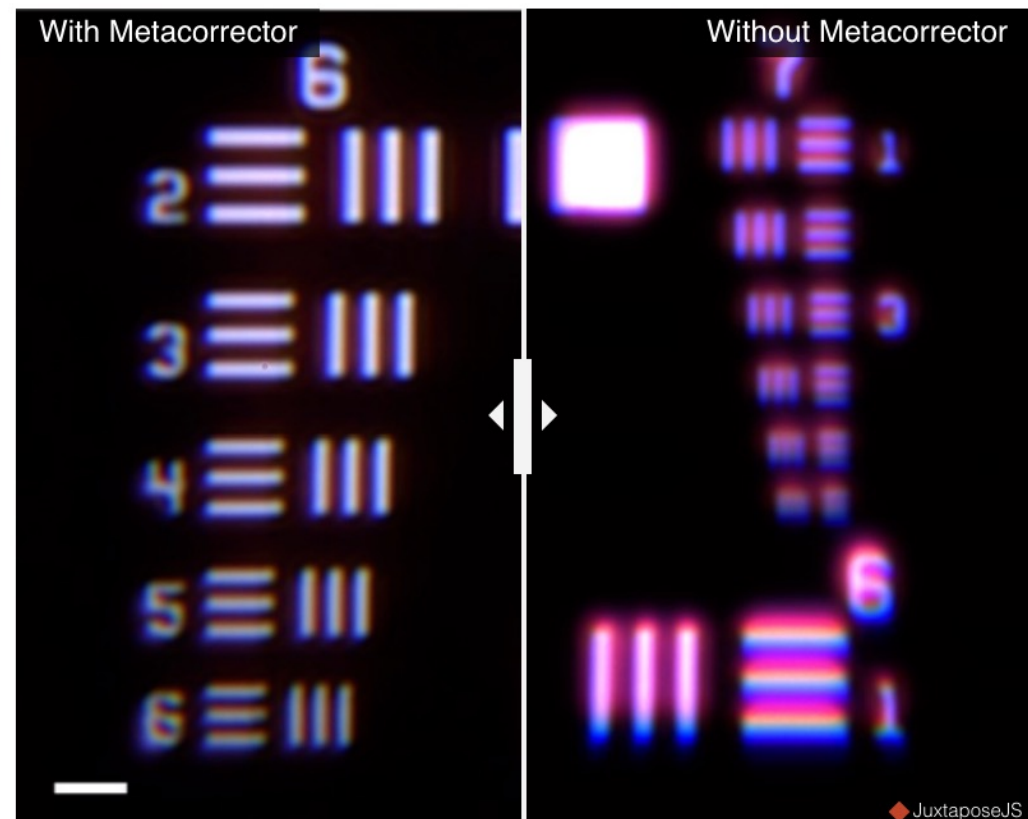

Distorsion

- „Verzeichnung“ des Objektivs
 - tonnenförmig
 - kissenförmig
- die berühmte Backsteinwand

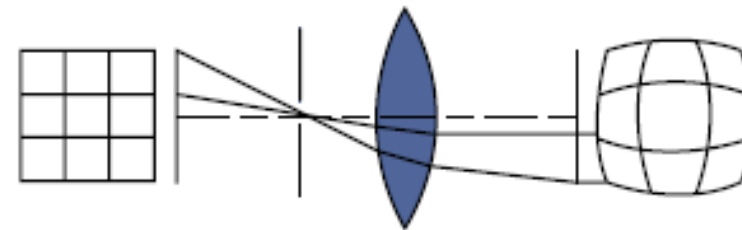

Tonnenförmige Verzeichnung

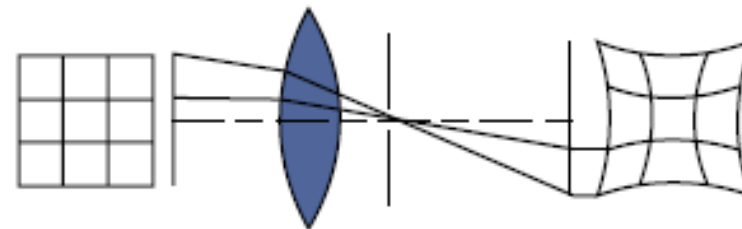

Kissenförmige Verzeichnung

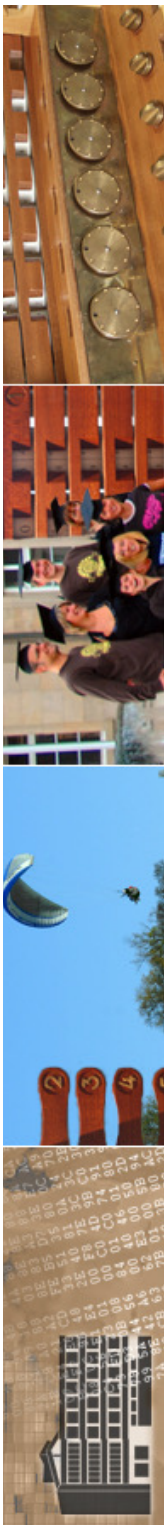

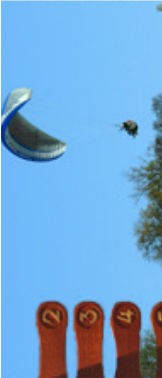



Lightroom

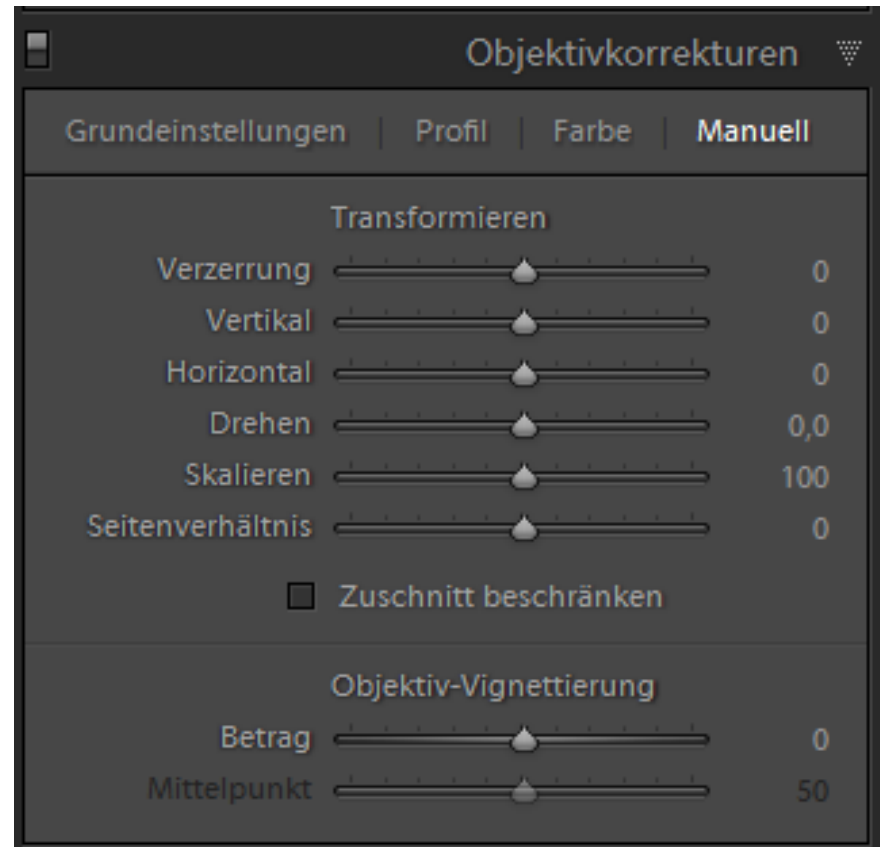
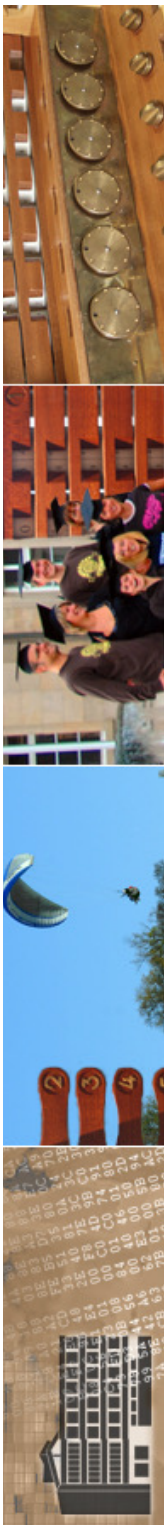

sphärische Aberration

- Abweichen durch „Linsendicke“

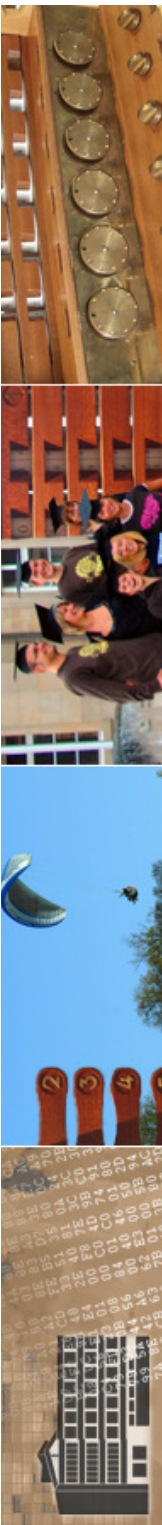
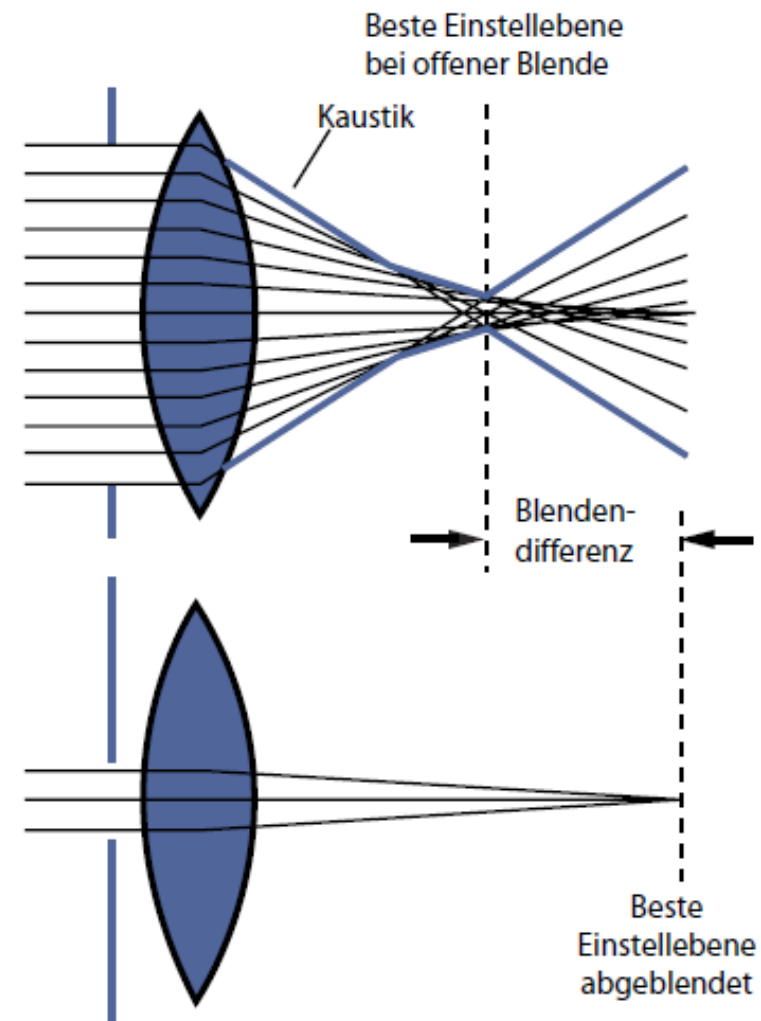



speziell Koma

- aus einer Lichtquelle (Punkt) wird ein „Kometenschweif“
 - Korrektur durch asphärische Linsen
 - wesentlich für Astrophysik

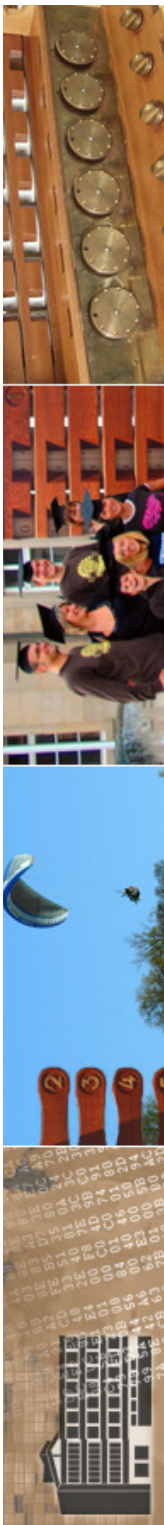

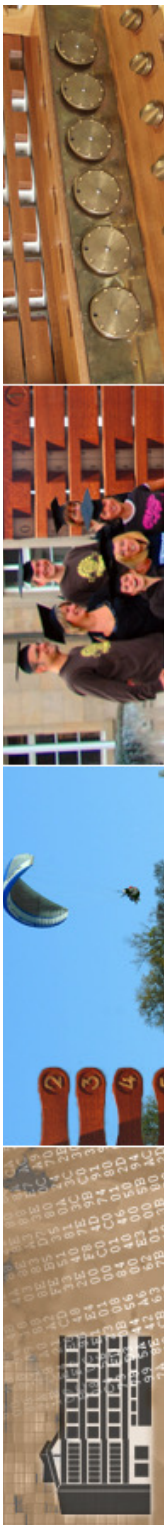

Center

Corner

f/1.8

f/2.5



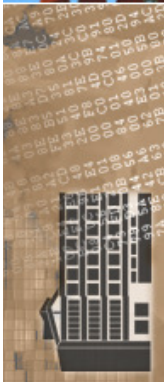
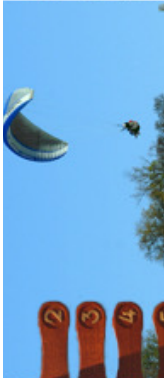

© 2023 Universität
Tübingen



asphärische Linsen

- asphärische Linsen steigern Abbildungsleistung wesentlich
 - ab ~ 1965 in Handarbeit
 - ab ~ 1995 industriell
 - zunächst extrem kostenaufwendig

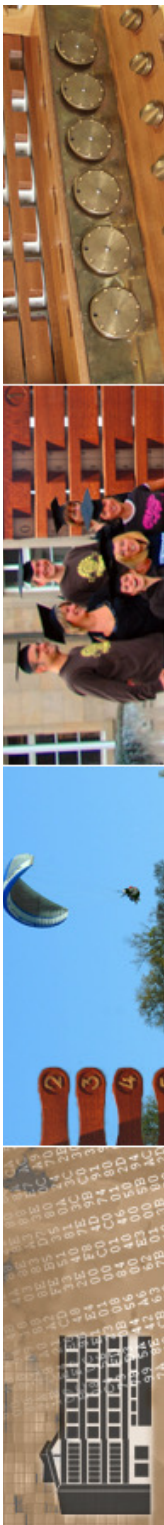
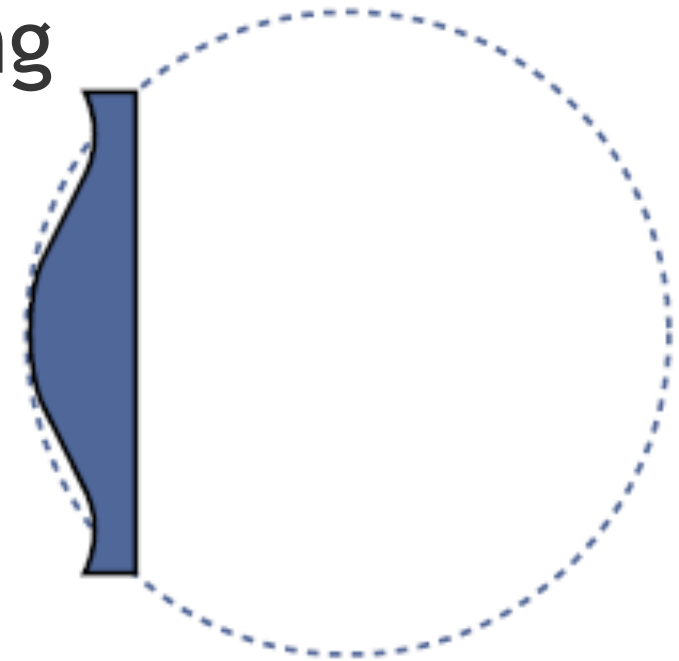



Leica Asphären Technologie

Onion Rings

| Parameter | Value |
|----------------------|-----------|
| APV | 6.114 µm |
| Line | 3.705 mm |
| Offset | +8.163 mm |
| Dist X | 29.7 mm |
| Dist Y | 29.7 mm |
| Radius (measured) | 0 mm |
| Radius (theoretical) | 0 mm |
| WaveLength | 633.00 nm |
| Dist. Diameter | 0 mm |



Vignettierung

- „Randabdunkelung“

– natürliche
Vignettierung:

$$d_2 = d_1 \cdot \cos \phi$$

$$A \cdot \cos \phi$$

– künstliche
Vignettierung

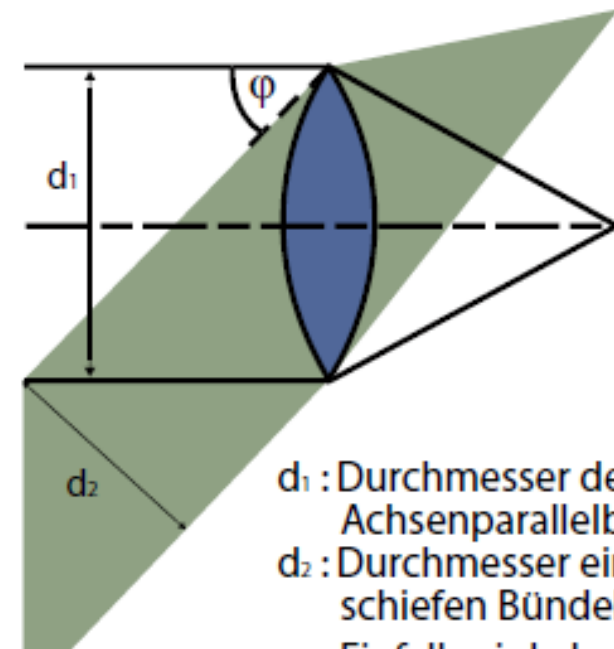

d_1 : Durchmesser des
Achsenparallelbündels
 d_2 : Durchmesser eines
schiefen Bündels
 ϕ : Einfallswinkel

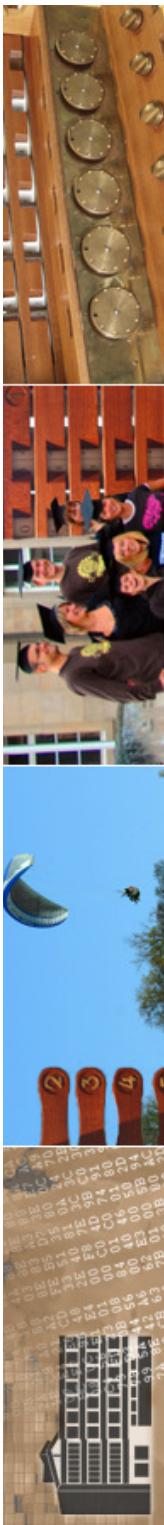



Reflexionen

- Brechzahl n

$$n = \frac{c_0}{c_m}$$

$$\frac{\sin \alpha_1}{\sin \alpha_2} = \frac{n_2}{n_1} = \frac{c_1}{c_2}$$

- Vergütung von Linsen
- Mehrfachvergütung
- erst damit ab ~ 1930 Objektive mit mehr als 5 Linsen

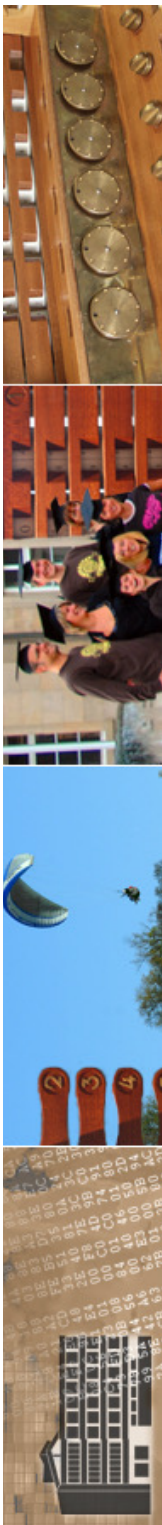

Vergütung von Linsen

- Antireflexbeschichtung



Erfindung durch den ukrainischen
Physiker Alexander Smakula
(Олександр Теодорович Смакула)

- ab 1934 bei Zeiss in Jena, dort 1935
Entwicklung entspiegelter Flächen
- 1951 Ruf an das MIT

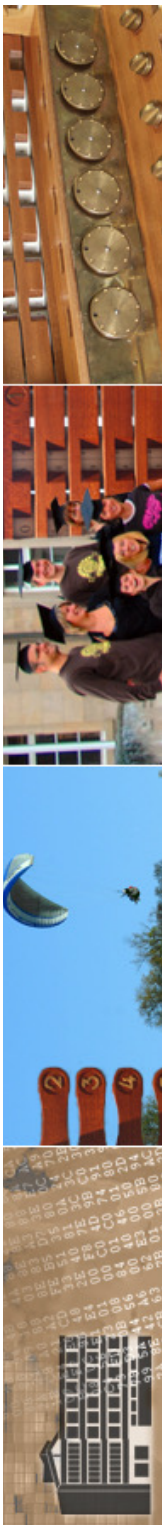



klassische Objektivkonstruktionen

- Ultra-Weitwinkel $< 24\text{mm}$
- Weitwinkel 24mm bis 50mm
- Normal 50mm
- Portrait-Tele 50mm bis 100mm
- Tele 100mm bis 300mm
- Super-Tele $> 300\text{mm}$

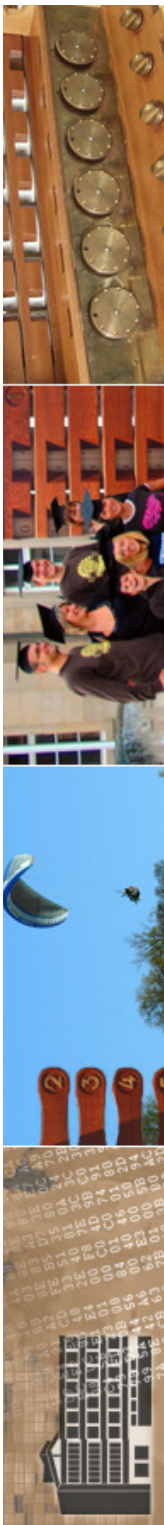



Bezeichnungen von Optiken

- *Zeiss*
 - Objektivname gibt Klasse des Optikaufbaus an
- *Leica*
 - Objektivname gibt Lichtstärke an
- alle anderen
 - Vielzahl von Abkürzungen wie DX, ED, IS, IF, VR, AF-S, DG, DN

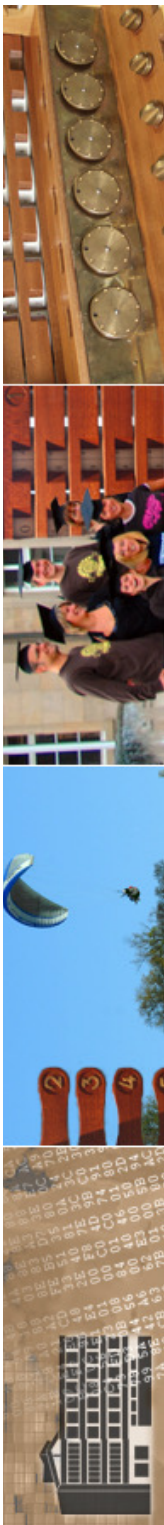

Cookesches Triplet

- früher Klassiker mit 3 Linsen

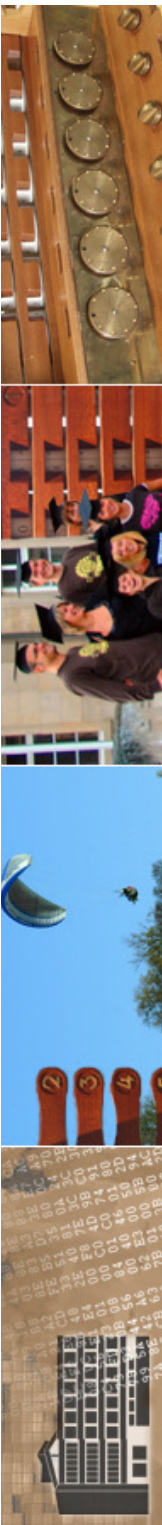
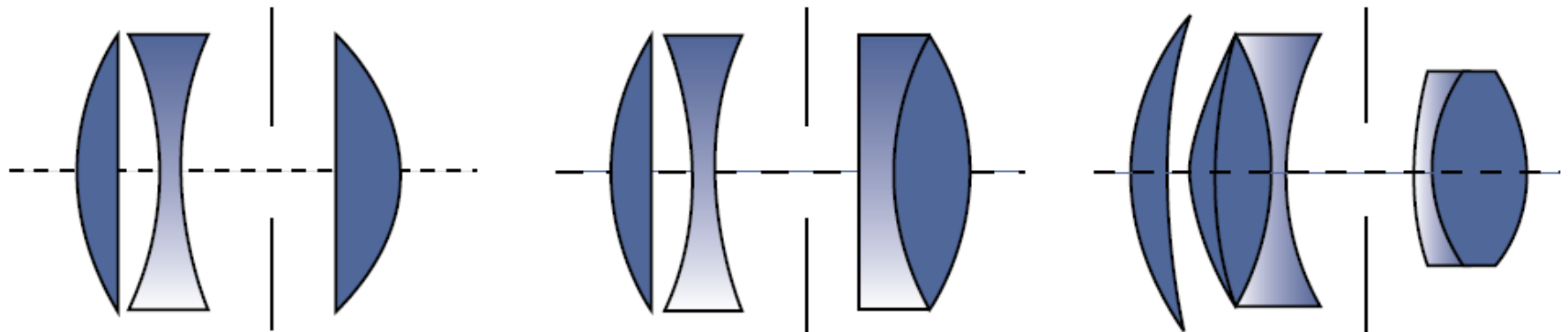

Gauß-Typ

- symmetrisches Objektiv

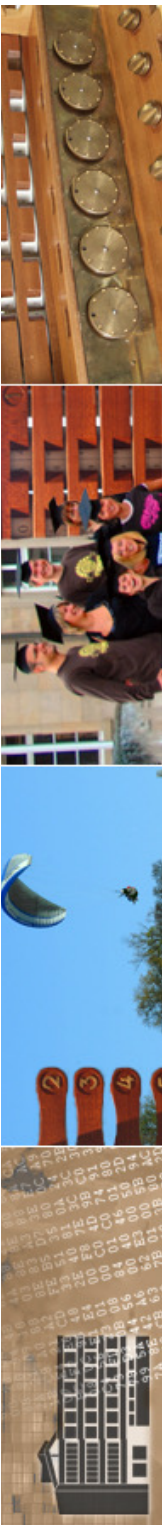
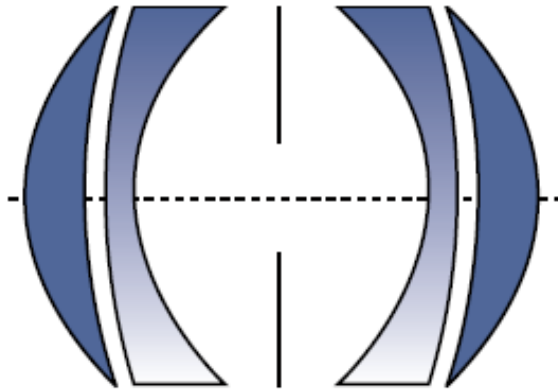

Retrofokus-Prinzip

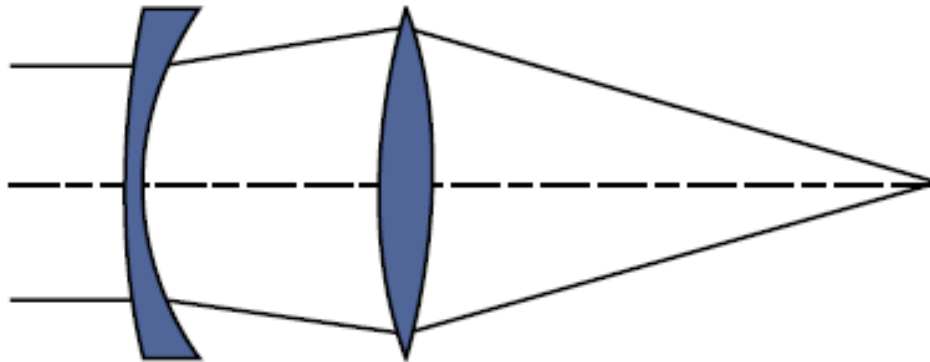

- erhöht Abstand hintere Linse - Sensor/Film
- verschlechtert optische Konstruktion
- wichtig für SLR bei Weitwinkel

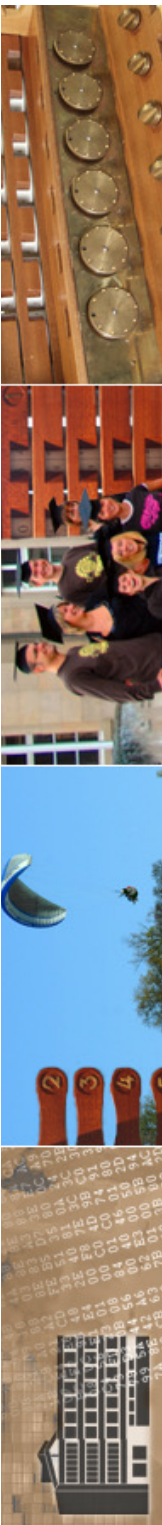

symmetrisch versus retrofokus

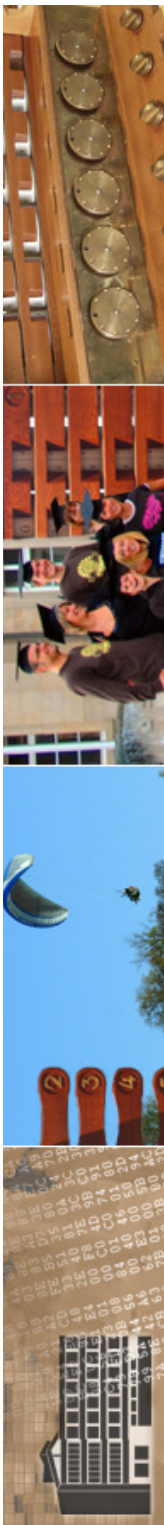

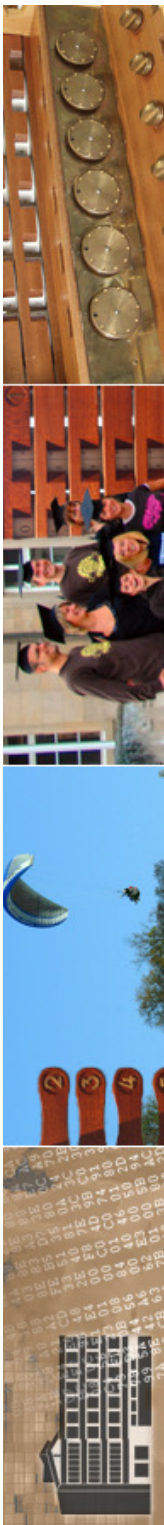



Beurteilung vom Objektiven

- Brennweite
- Lichtstärke
- MTF-Kurven
- Distorsion
- Vignettierung

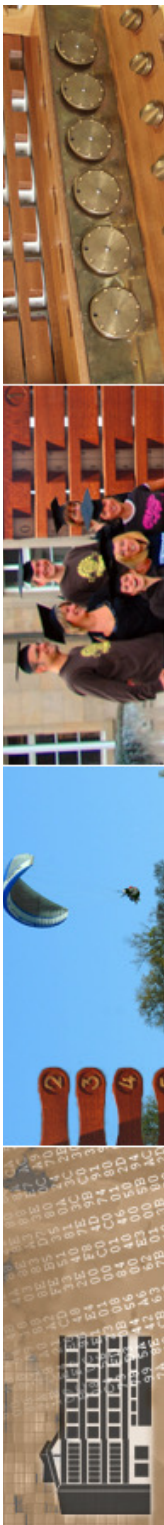



MTF-Kurven

- Modular-Transfer-Funktion

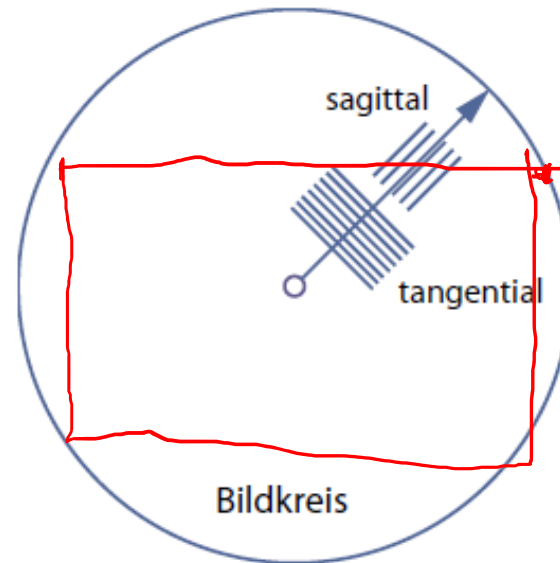

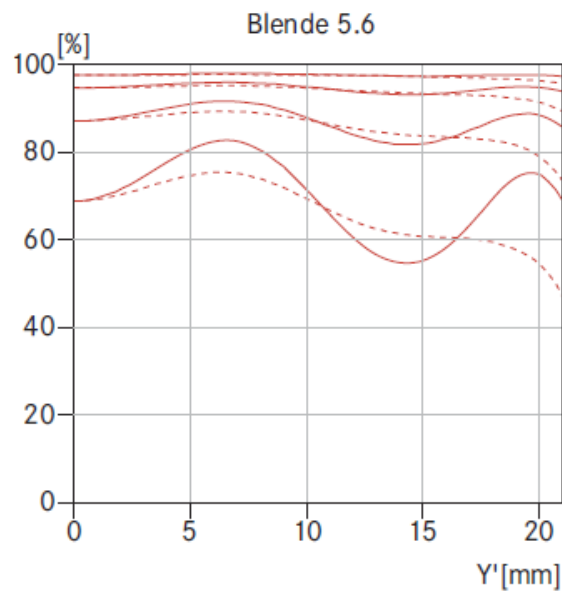
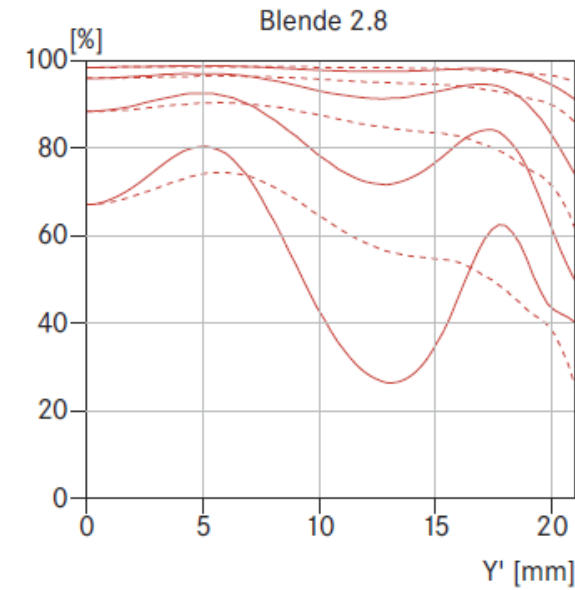
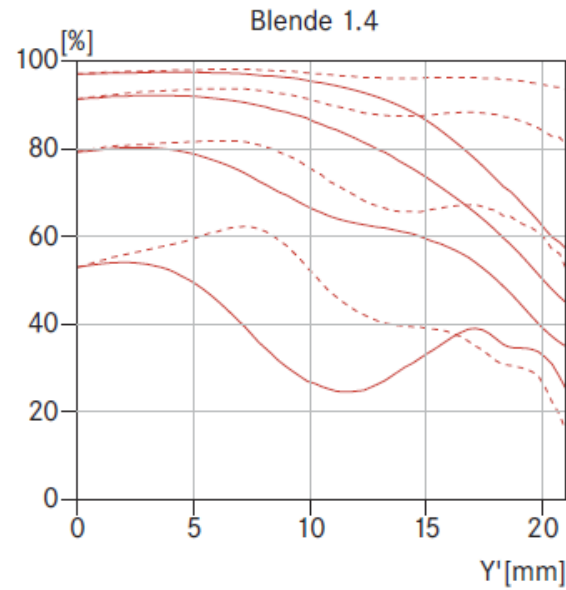
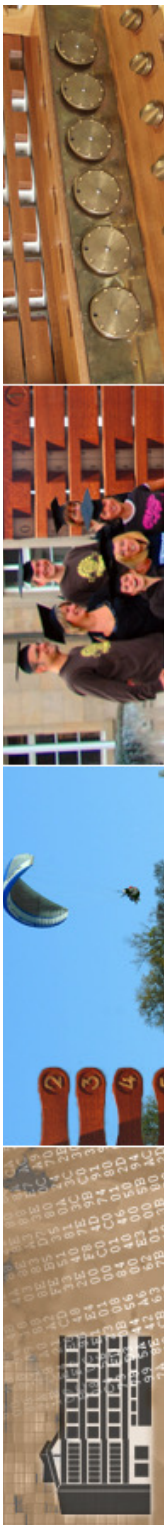

Die MTF ist jeweils für die volle Öffnung, für die Öffnung 2,8 und für die Öffnung 5,6 für große Aufnahmeentfernungen (unendlich) angegeben. Aufgetragen ist der Kontrast in Prozent für 5, 10, 20, 40lp/mm über die Höhe des Kleinbildformats für tangentielle (gestrichelte Linie) und sagittale Strukturen(durchgezogene Linie) bei weißem Licht. Die 5 und 10lp/mm geben einen Eindruck über das Kontrastverhalten für gröbere Objektstrukturen, die 20 und 40lp/mm dokumentieren das Auflösungsvermögen feiner und feinsten Objektstrukturen.

— sagittale Strukturen
- - - tangentielle Strukturen



MTF-DIAGRAMME

Unendlich (∞)

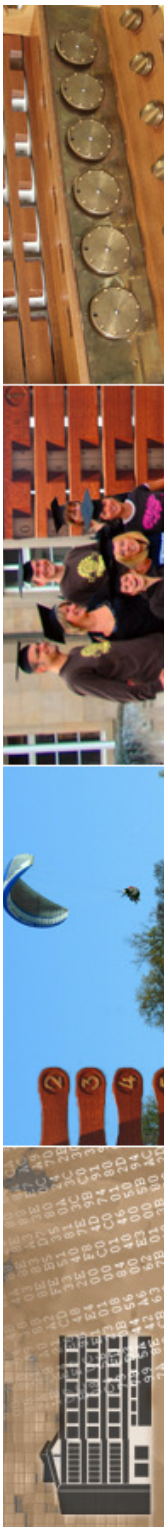

Brennweite 24 mm

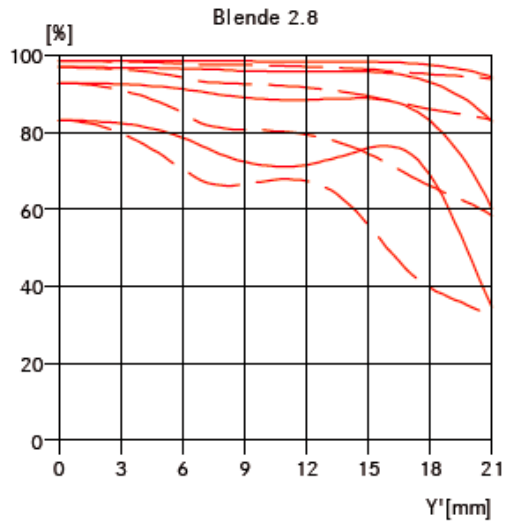

Brennweite 50 mm

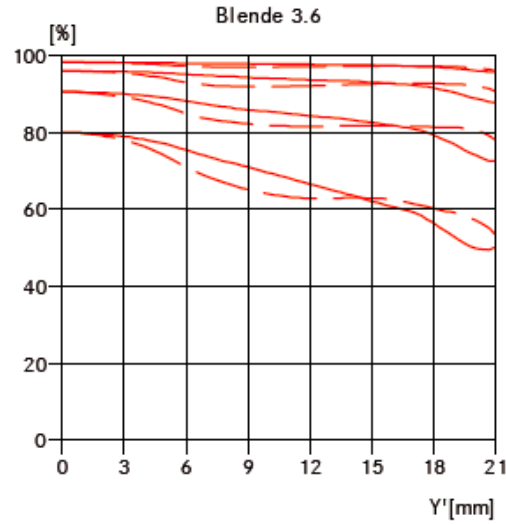

Brennweite 90 mm

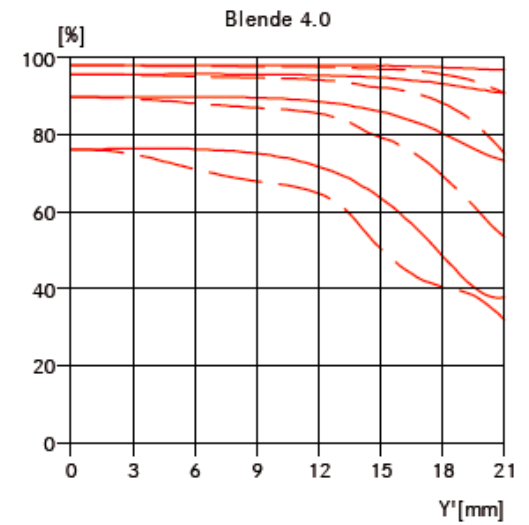

Blende 5.6

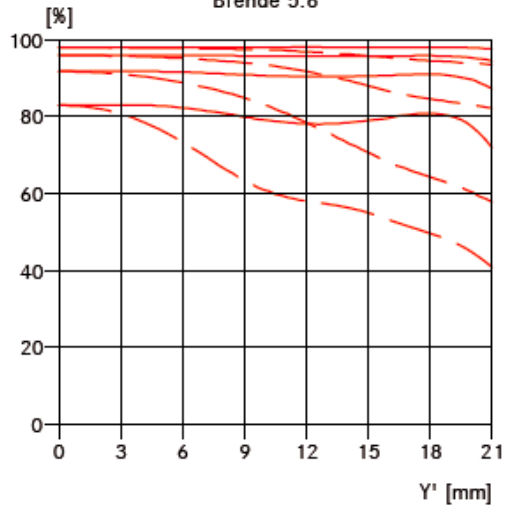

Blende 5.6

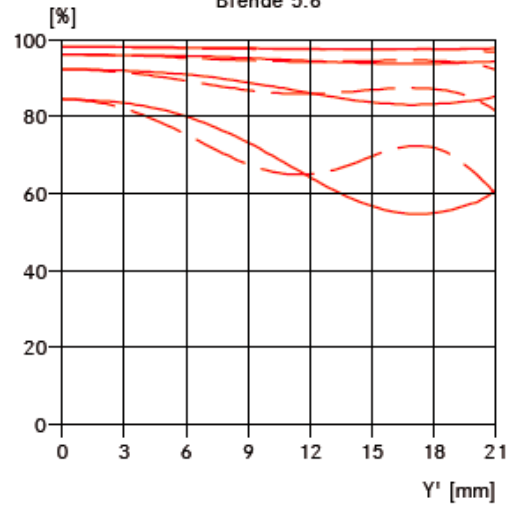

Blende 5.6

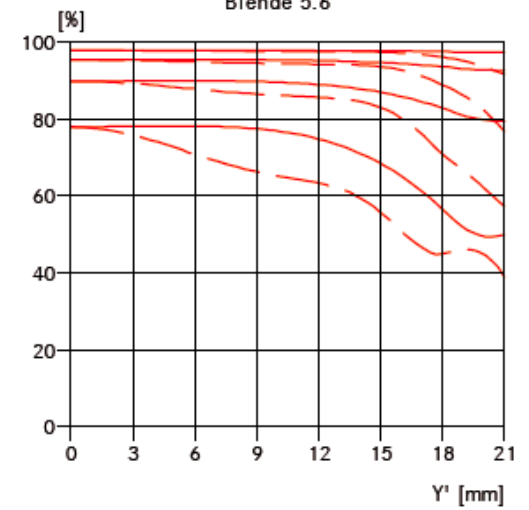

Blende 8.0



Blende 8.0

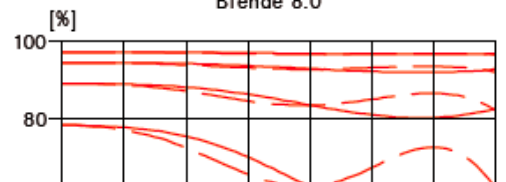

Blende 8.0



Beispiel Sigma

Leistungsmerkmale

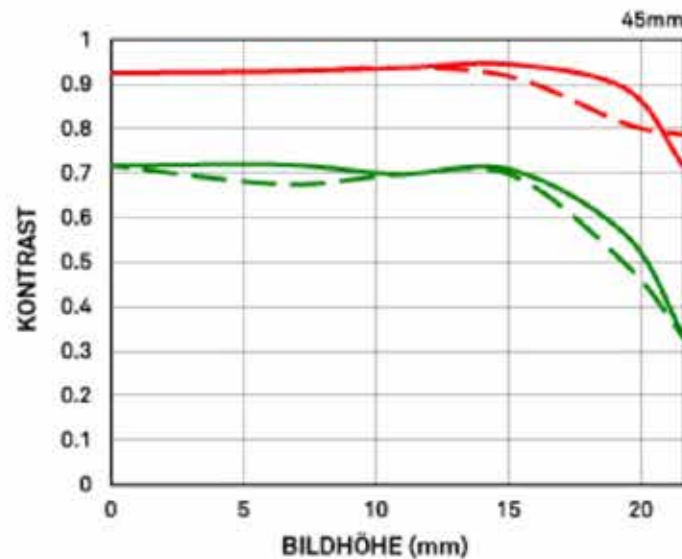

MTF-Diagramm Beugung: 45mm F2,8 DG DN | Contemporary

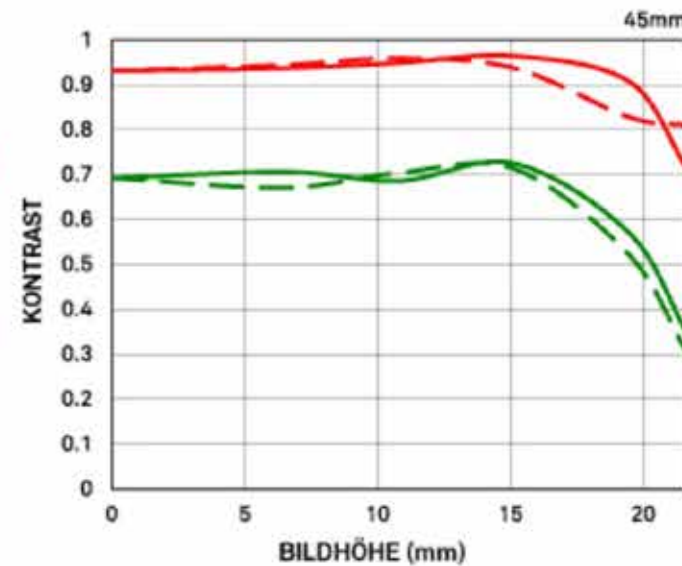

MTF-Diagramm Geometrisch: 45mm F2,8 DG DN | Contemporary



andere Darstellung

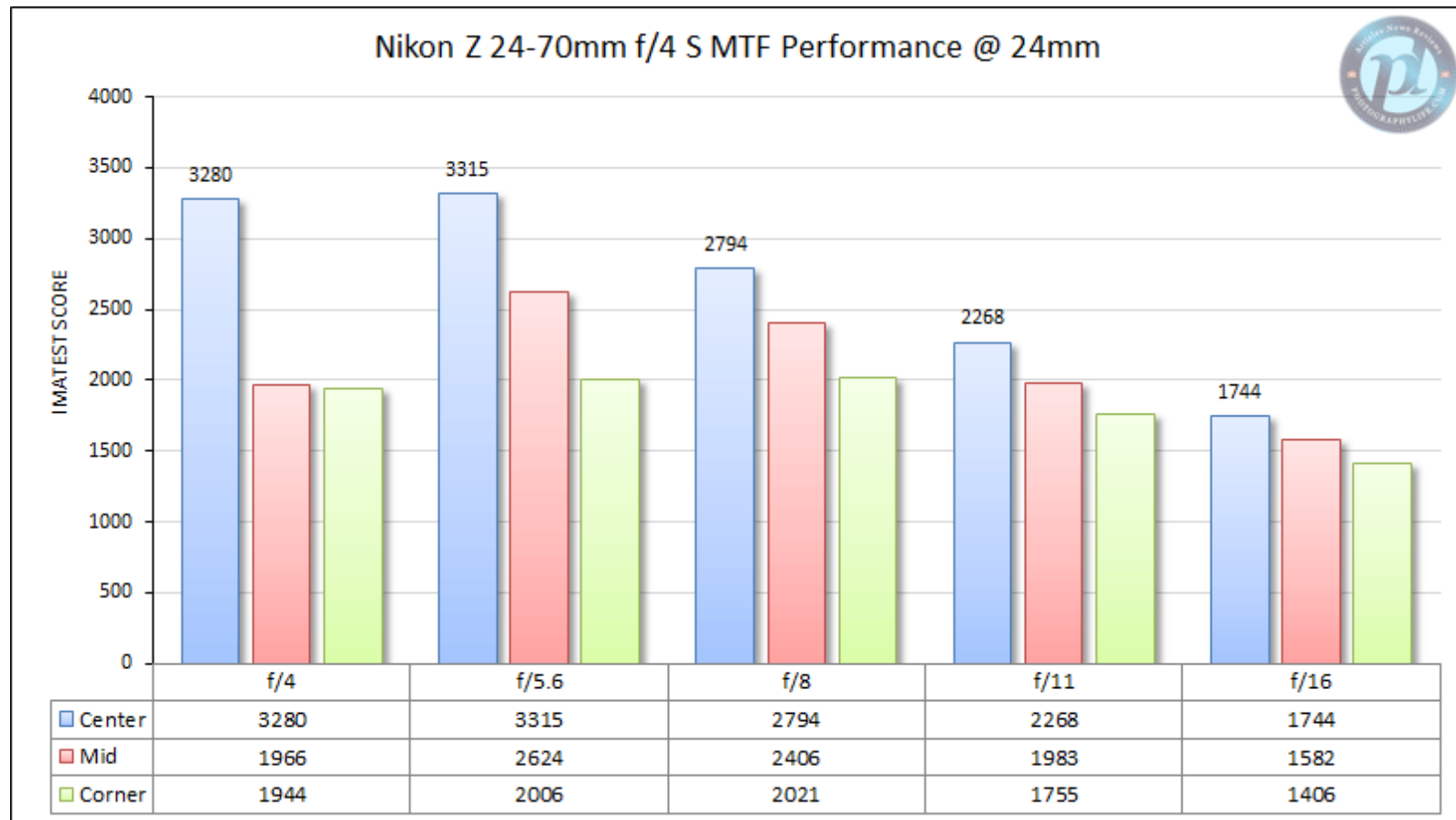

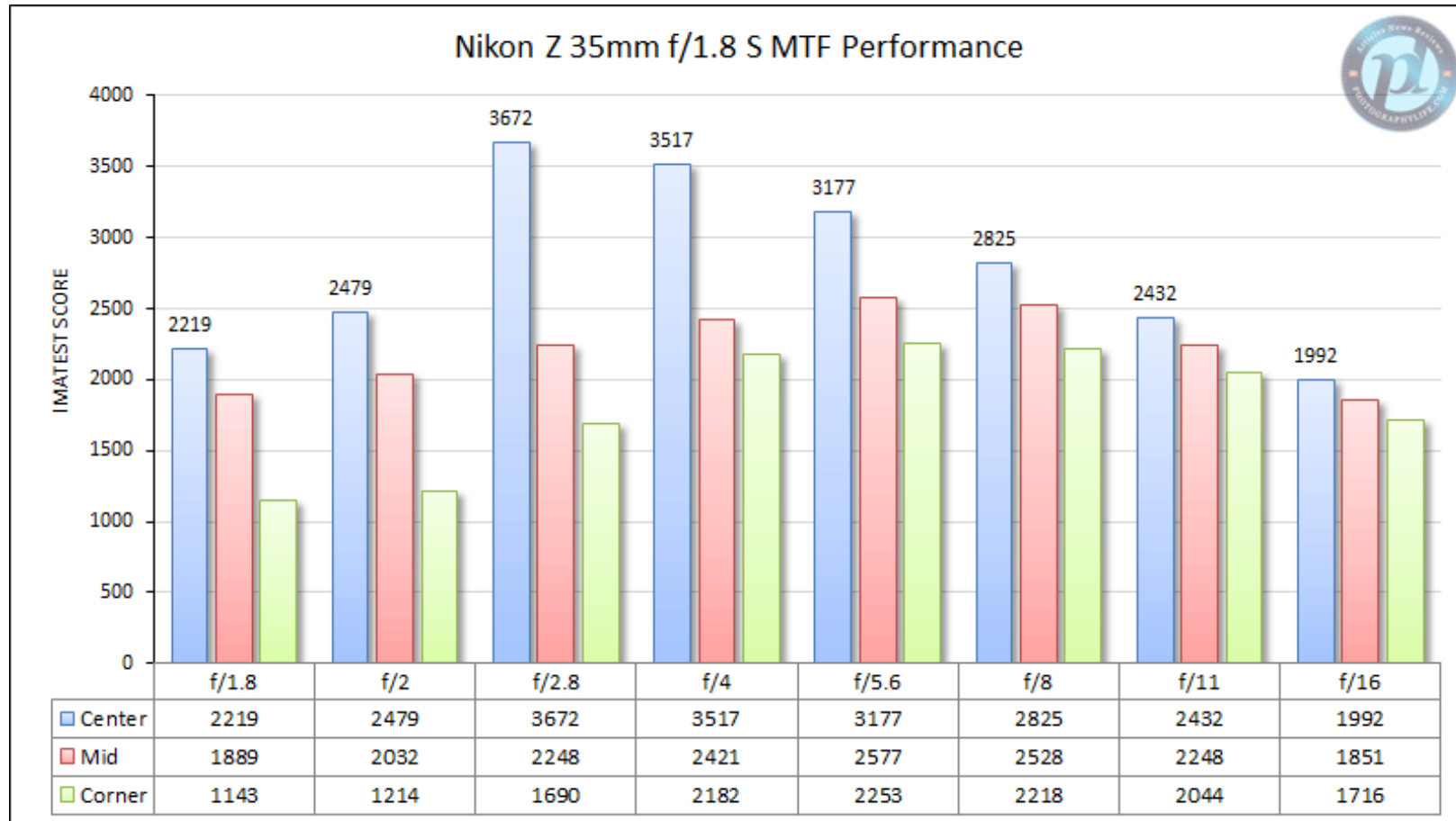
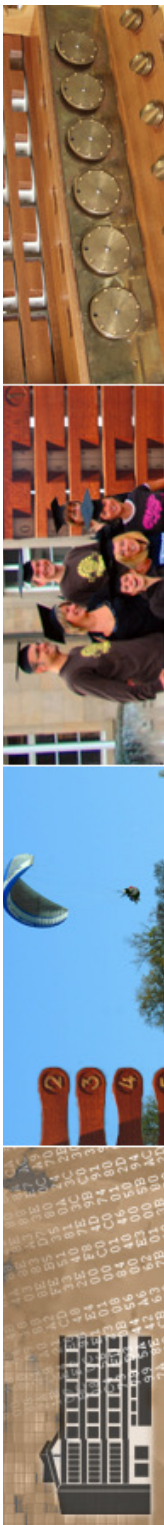

ein (extremes) Beispiel



APO-SUMMICRON-SL 1:2/35 ASPH.

Technische Daten.

TECHNISCHE ZEICHNUNG



Abbildung 1:2

LINSENSCHNITT

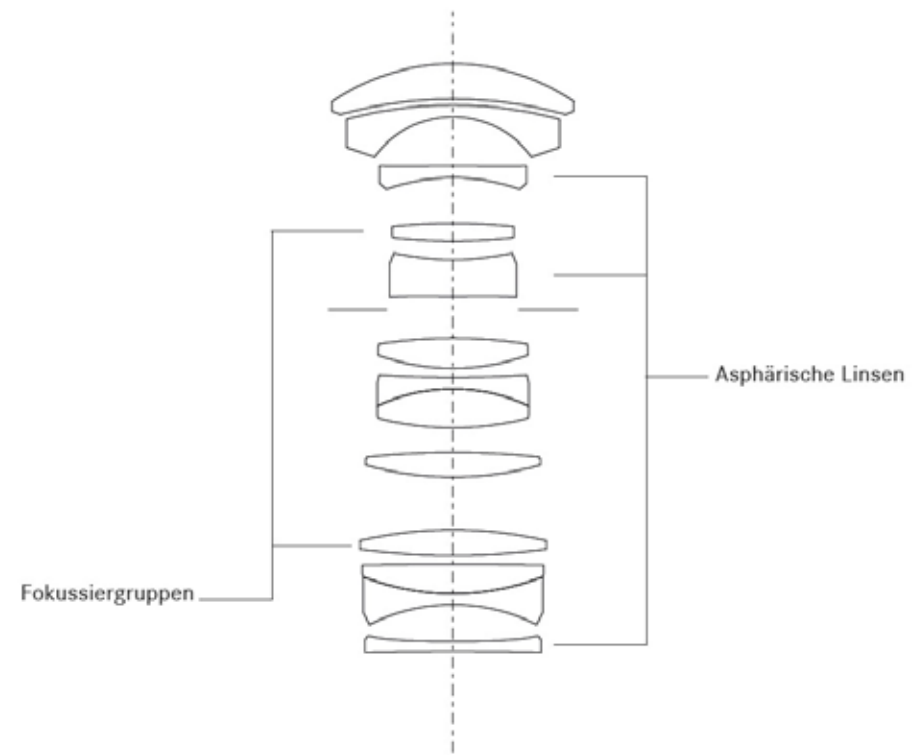

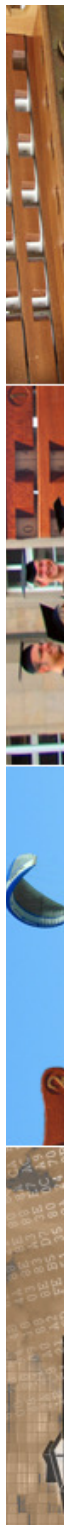

Unendlich (∞)

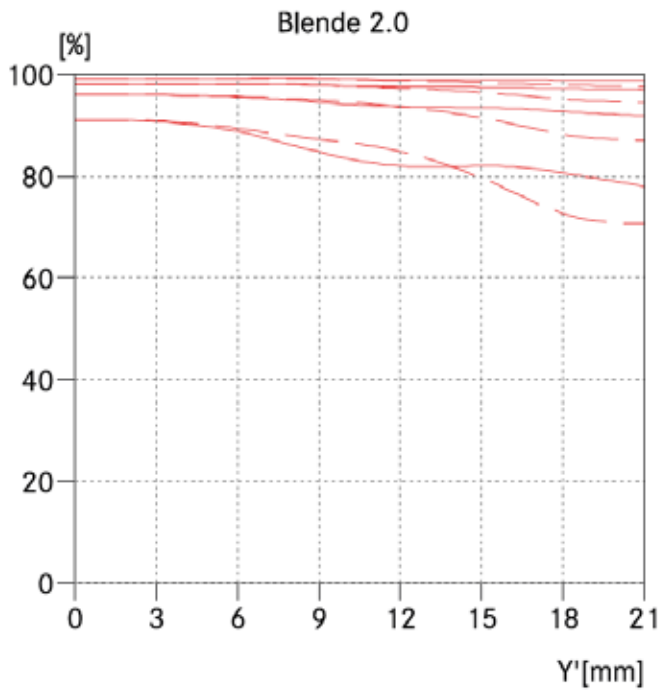

Naheinstellung (0,5 m)

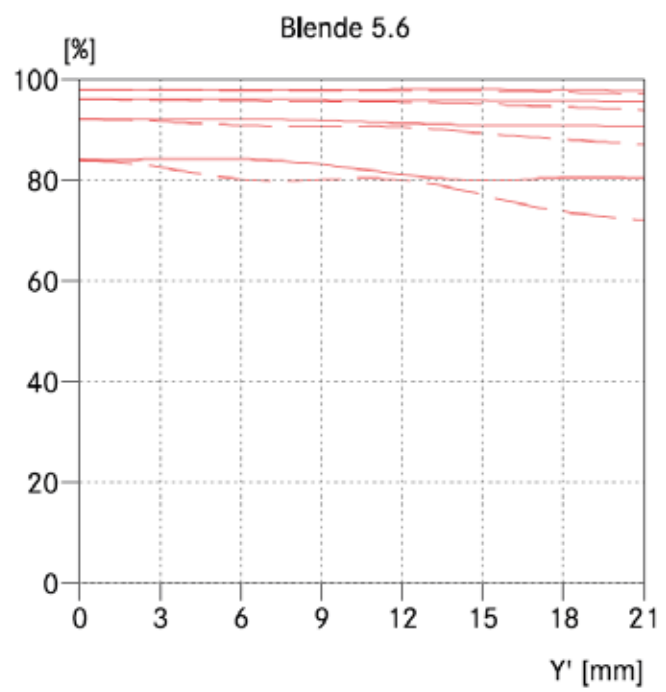
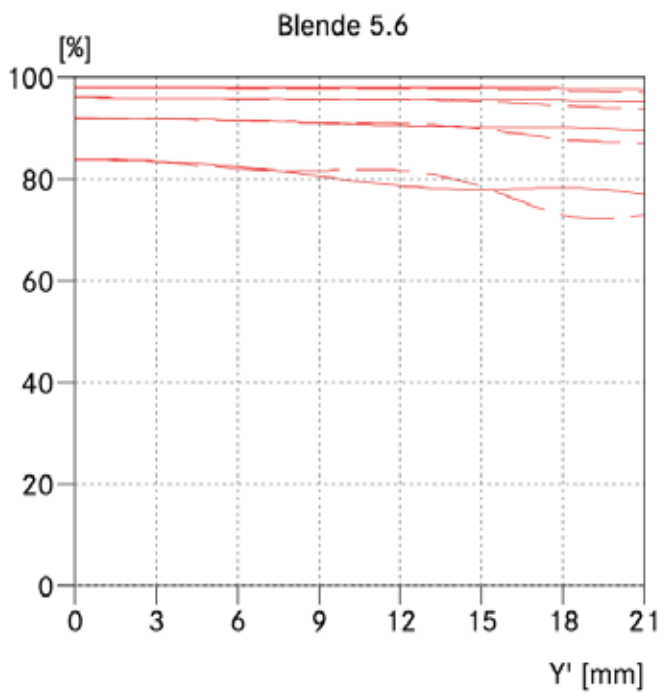
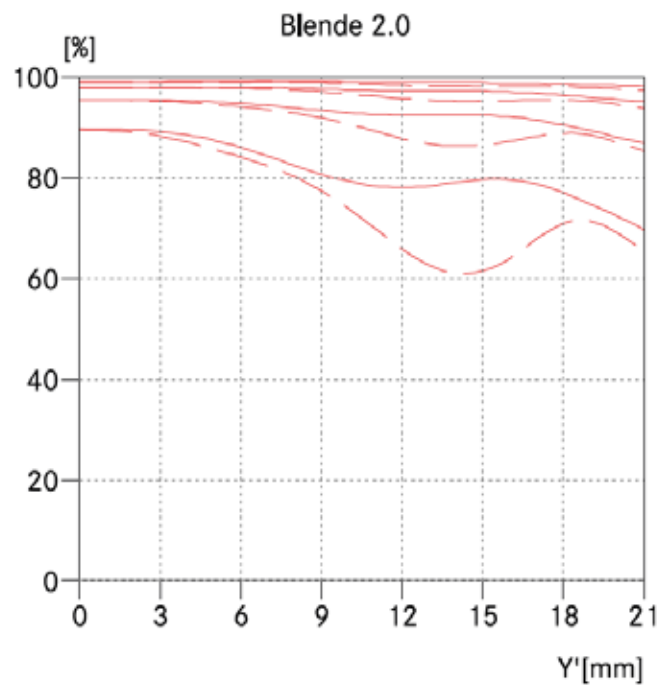

02.11.2022: Nikkor 600mm/4,0

- Nikon stellt am 02.11.2022 das neue Nikkor Z 600mm/4,0 TC VR S vor

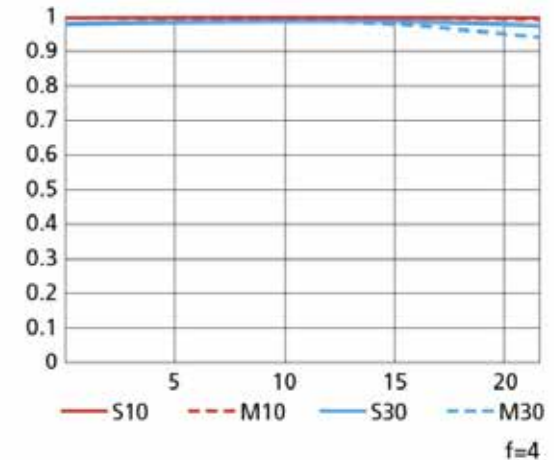

When not using the built-in teleconverter



- SR lens
- fluorite lens
- Super ED lens
- ED lens

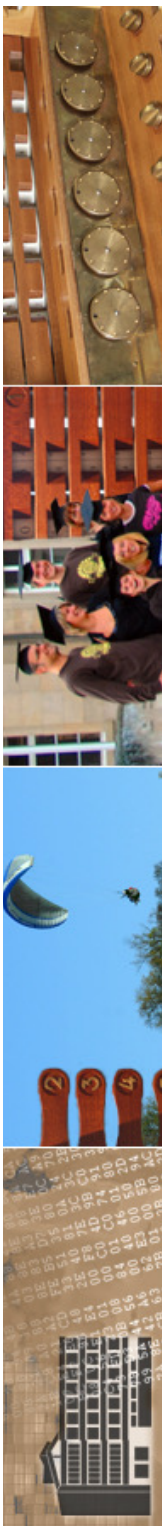

Planar

- Verbesserung des Gauß-Typs
- Klassiker für Normal-Brennweite

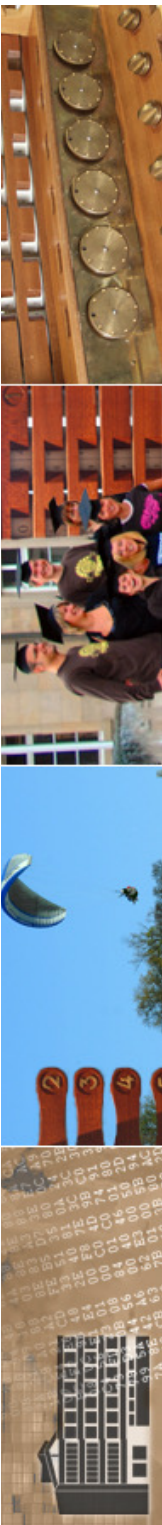
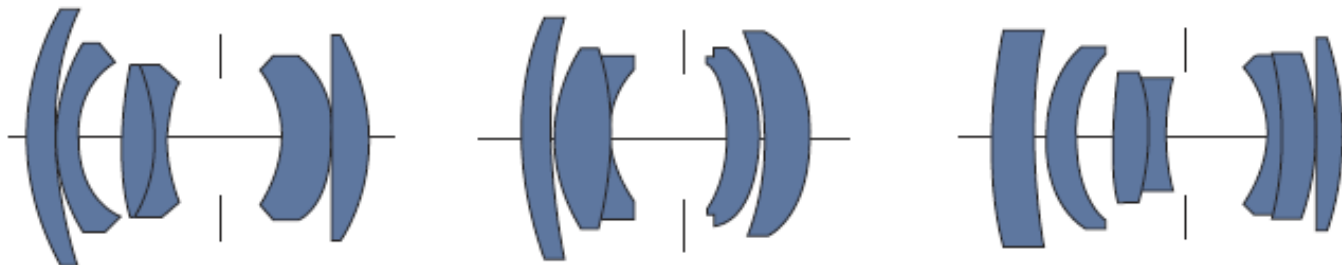
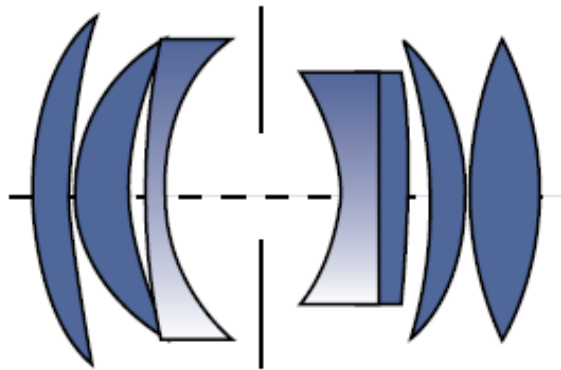

eine aktuelle Rechnung



Nikkor Z 50/1,8 S

Lens Construction

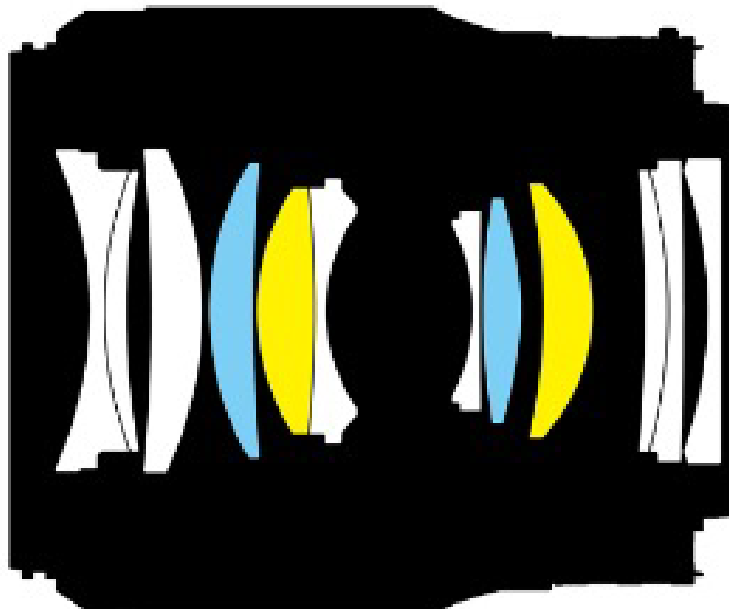

ED glass elements



Aspherical lens elements

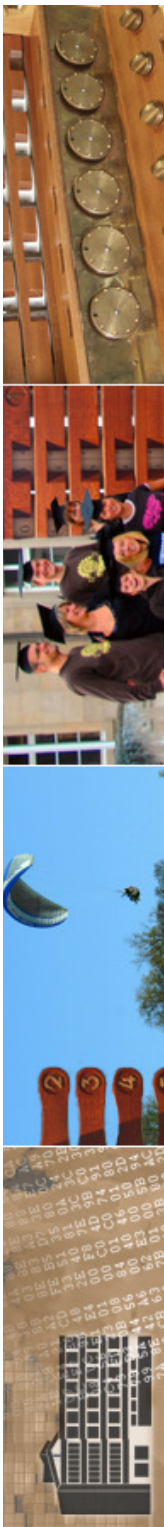

Why are modern 50mm lenses so damned complicated?

908

Published May 9, 2021 | [RCicala](#)

Share

Tweet



Lenses like Nikon's Z 50mm F1.2 S are bigger, heavier, more costly and more complex than older F1.2 designs. But why?



moderne „Normalobjektive“

- https://www.dpreview.com/opinion/9236543269/why-are-modern-50mm-lenses-so-damned-complicated?utm_source=self-desktop&utm_medium=marquee&utm_campaign=traffic_source

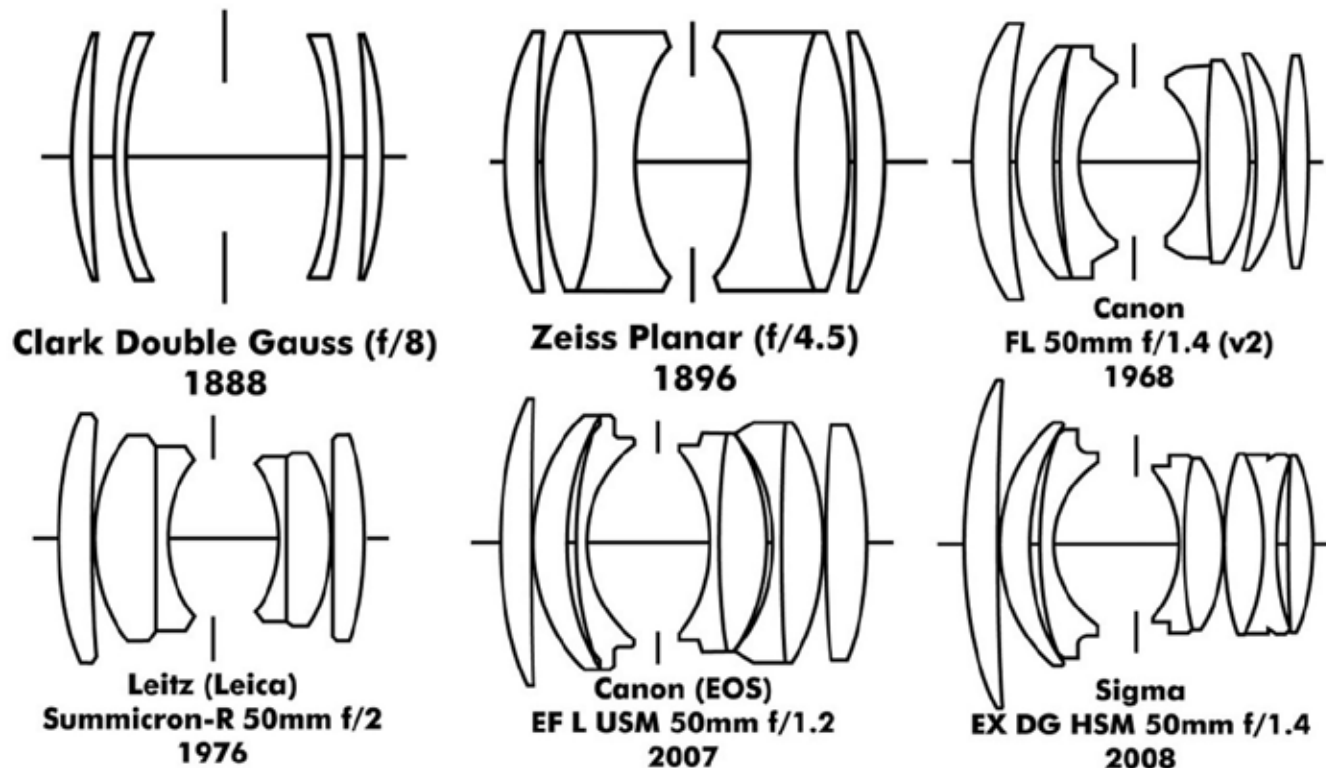



But lenses change

In the last decade, 50mm lenses have gotten more complex. Compare the 30 year old design of the Canon 50mm F1.2 (right) with the more recent Sigma 50mm F1.4 Art and Zeiss Otus 55mm F1.4 (left) designs.

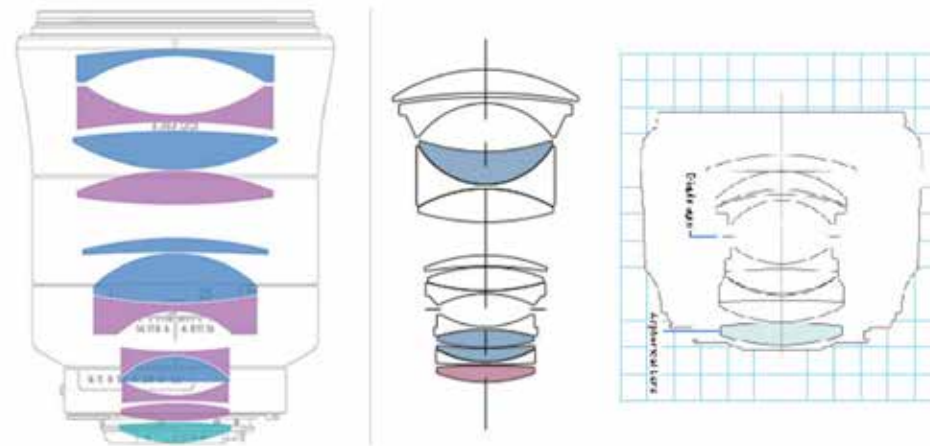

Lens diagram of (left to right) Zeiss 55mm Otus, Sigma 50mm F1.4 Art, and Canon 50mm EF F1.2L lenses.

Three major manufacturers have recently introduced even more complex-design 50mm F1.2 lenses, containing 13 to 18 elements with multiple aspheric and low dispersion elements. Any double Gauss influence on the design is pretty hard to see.

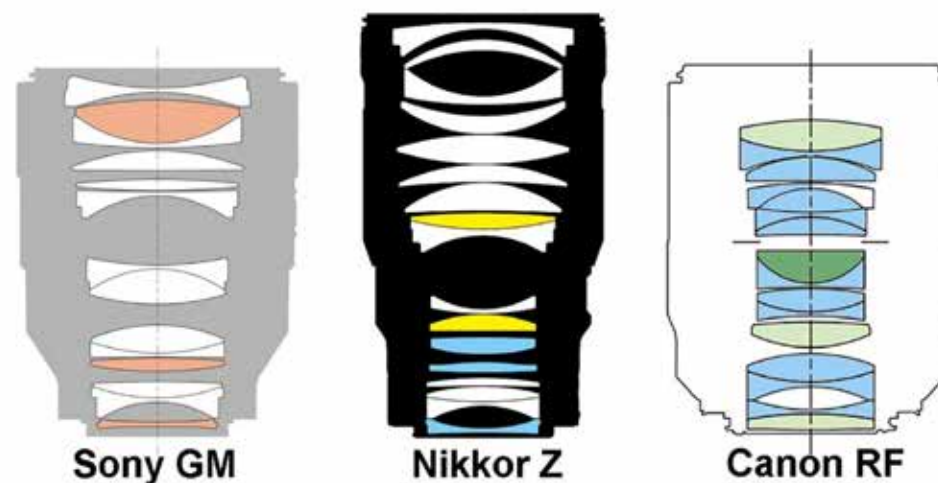

Lens diagrams of (from left): Sony FE 50mm f1.2 GM, Nikkor Z 50mm f1.2 S, and Canon RF 50mm f1.2L. (from manufacturer).

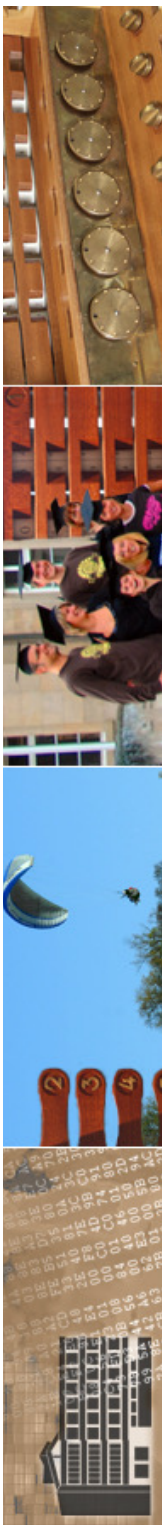



Sonar

- leichtes Tele

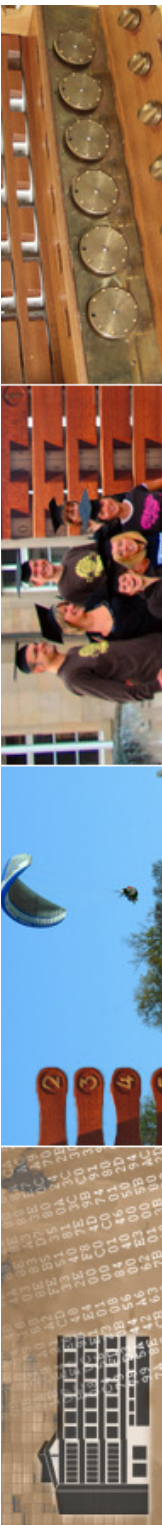
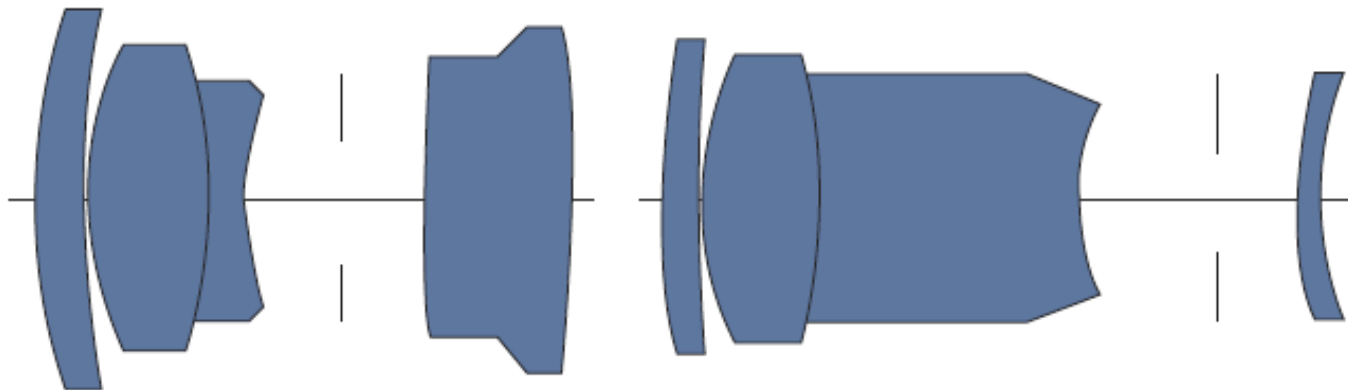

Sonar

- das klassische „Portrait-Tele“

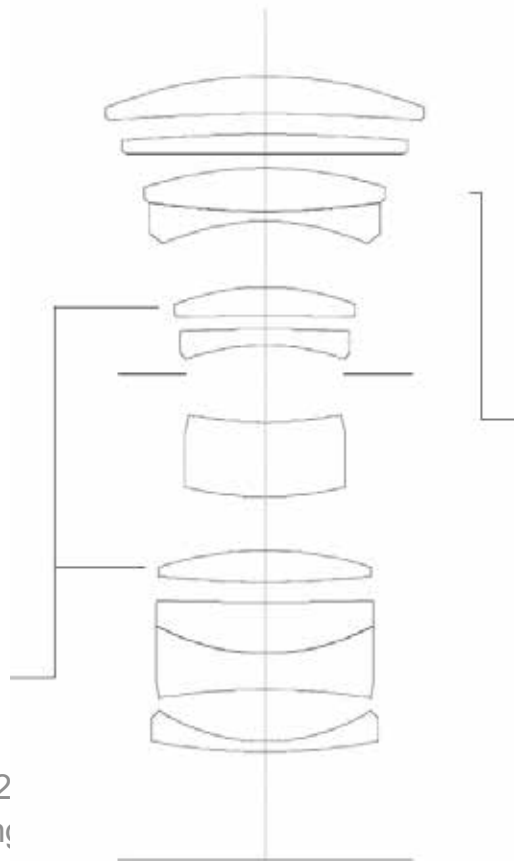

Tessar

- starkes Tele

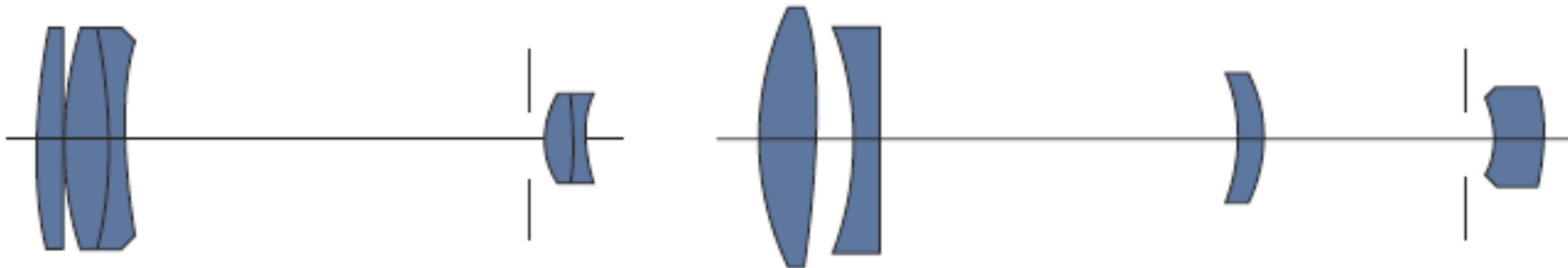

<https://zeissikonveb.de/start/objektive/normalobjektive/tessar.html>

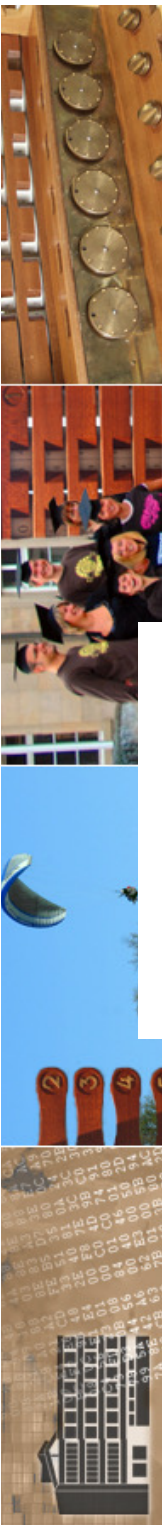



Tessar

Tessar 3,5/75 mm

Rechnung vom 28. Mai 1947

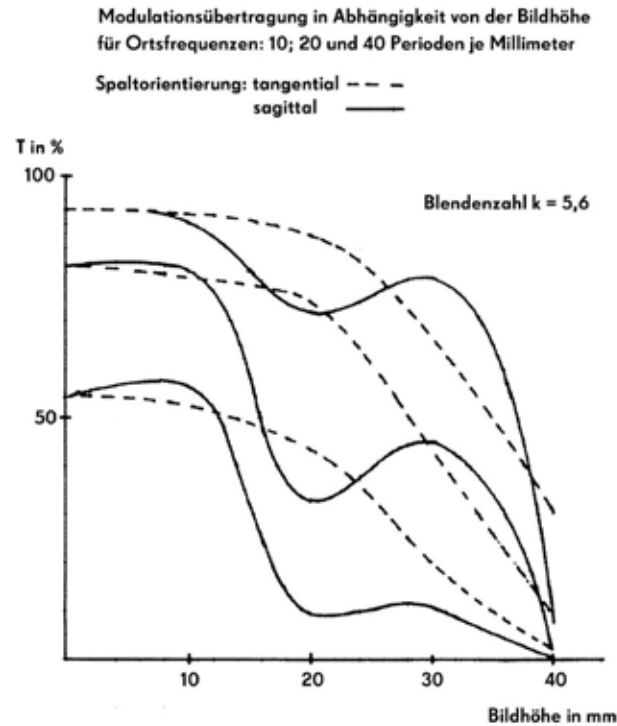
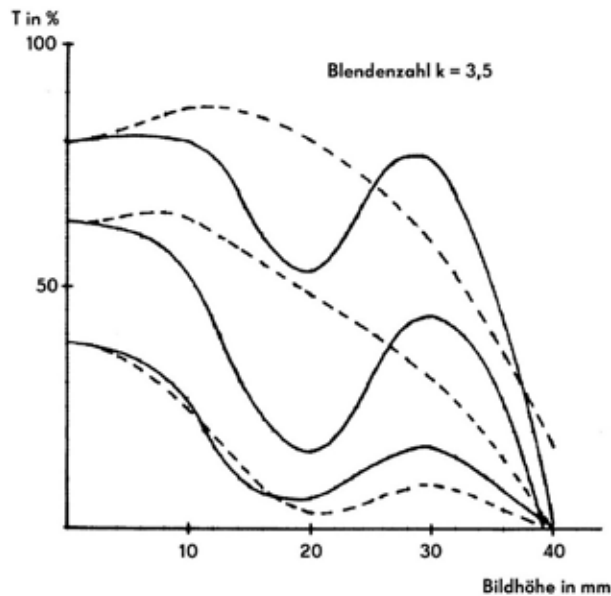

Das Auge Ihrer Kamera

ist das Objektiv. Wie der Mensch in seinem ganzen Tun auf die volle Sehkraft seiner Augen angewiesen ist, so ist auch die beste Kamera in erster Linie von der Leistungsfähigkeit ihres Objektivs abhängig. Je besser das Objektiv, desto schönere Bilder beschert uns die Kamera, um so größer ist die Freude ob des guten Gelingens. Daher rüsten die größten Kamera-Fabriken des In- und Auslandes ihre Apparate mit ZEISS-TESSAREN aus, den feinsten und zuverlässigsten Kamera-Augen der Welt.

Wählen Sie die Kamera mit

ZEISS TESSAR

Lichtstärken 1:2,7 * 1:3,5 * 1:4,5 * 1:6,3

Das ideale Objektiv für alle Zwecke der Photographie.

Alle Photo-Fachgeschäfte liefern gute Marken-Kameras ausgestattet mit Zeiss Objektiven.

Ausführlicher Katalog P.11. kostenfrei von Carl Zeiss, Jena, Berlin, Hamburg, Köln, Wien.



Distagon (1952)

- Weitwinkel in Retrofokus

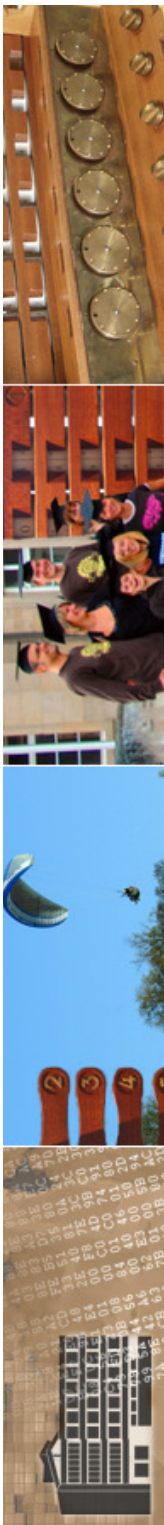
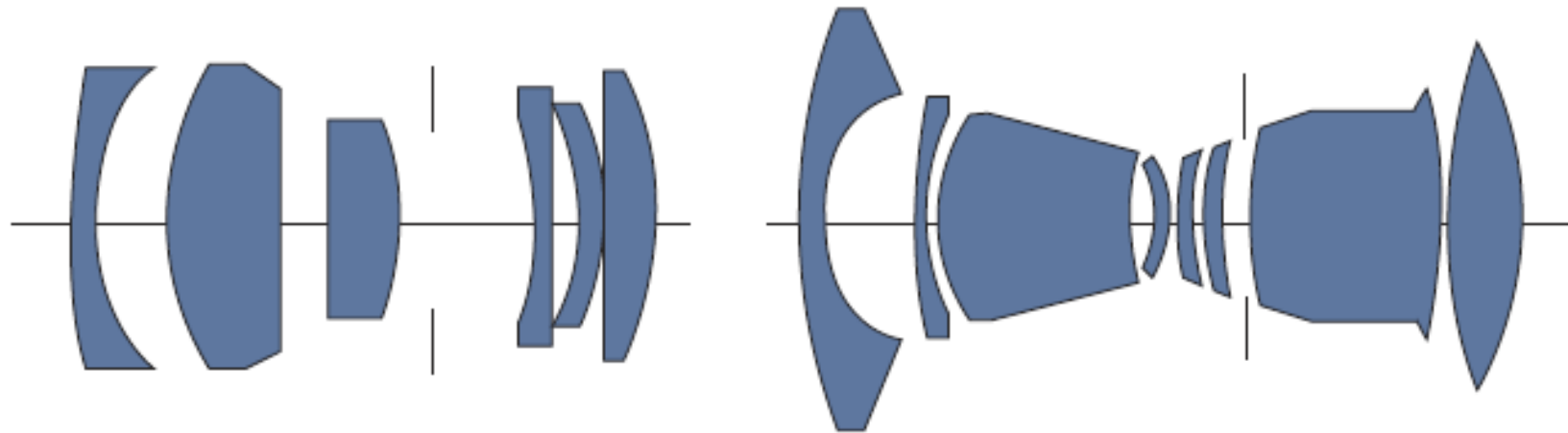

Biogon (1951)

- symmetrisches Weitwinkel ohne Retrofokus

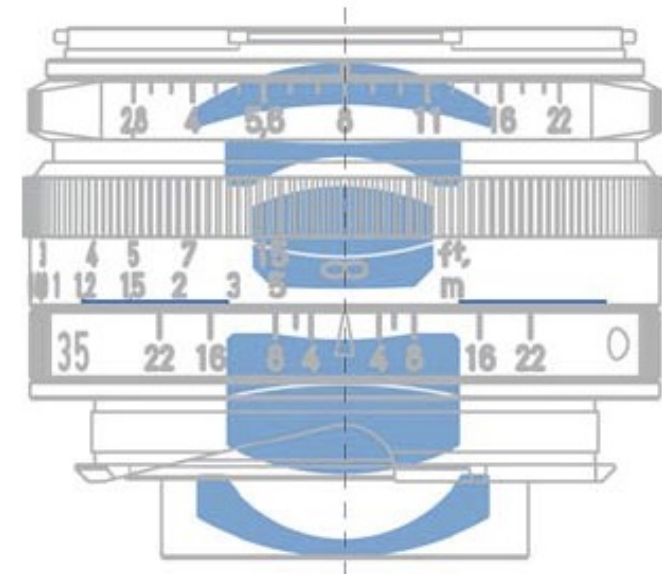



Biogon

- The name “Biogon” was used for the first time in 1936 for a 2.8/35 mm lens for the Contax rangefinder camera, also designed by Ludwig Bertele. Its name also includes the final syllable “gon”, referring to the angle. Of course, the syllable “bio” had a different meaning than today, which is often associated with foodstuffs in Germany and elsewhere. At that time it was often used to express the possibility of very dynamic photography and referred to quite different technical properties of the lens.

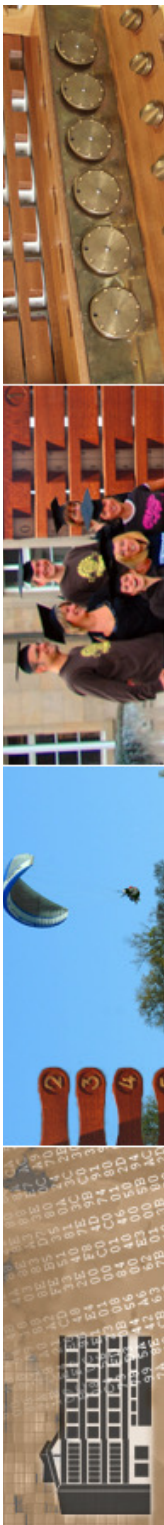

Biogon versus Distagon

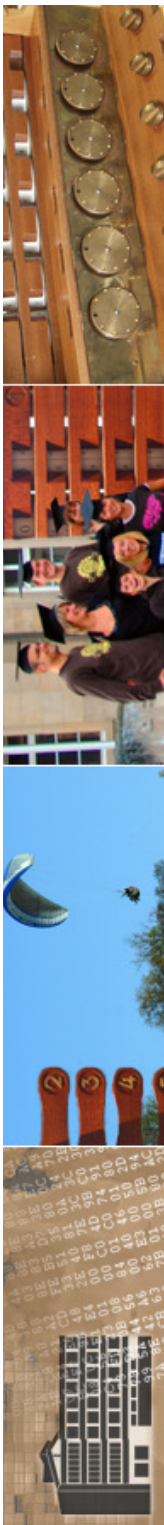

eine Legende

- Hasselblad 903: das Objektiv ist Kamera
– Biogon 4,5/38

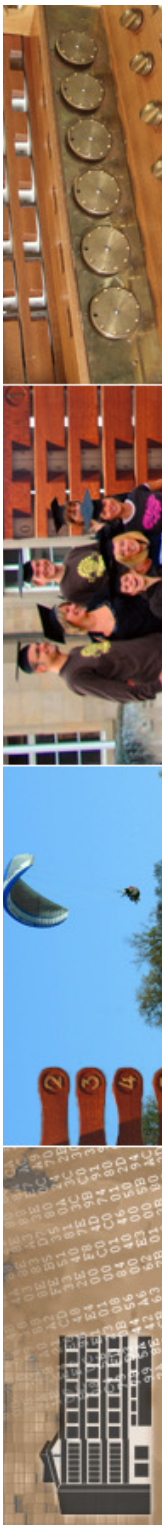



© KenRockwell.com

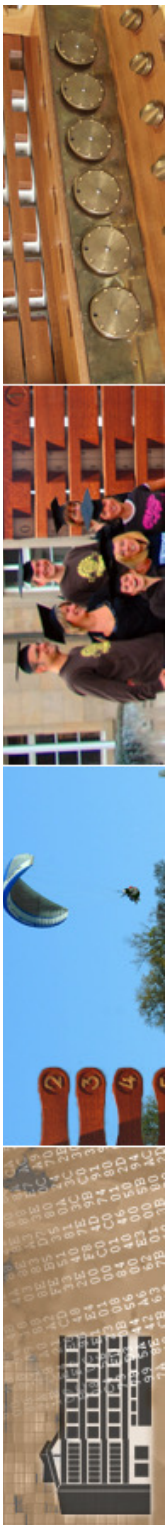



Mittelformatkamera Hasselblad 907X 50C: Renaissance eines Klassikers

Die Hasselblad 907X 50C will an das analoge Mittelformat digital anknüpfen, kann aber auch als eigenständiges Retro-Modell eingesetzt werden.

Lesezeit: 4 Min.  In Pocket speichern

   63



(Bild: Produktfoto: Hasselblad, Hintergrund: Christine Bruns)

06.11.2020 11:00 Uhr | c't Fotografie

Von Christine Bruns

Hasselblads analoge Mittelformatkameras landeten mit der einsetzenden Digitalisierung vielfach im Schrank, zu schade zum Weggeben, zu analog, um damit weiterzuarbeiten. Mit der Zeit kamen die ersten digitalen Rückteile auf den Markt. Anfangs mit zwei bis acht Megapixeln, später auch mit deutlich mehr. Hasselblad selbst entwickelte die CFV-Reihe, von der es bisher ein Rückteil mit 39 und eines mit 50 Megapixeln gab.

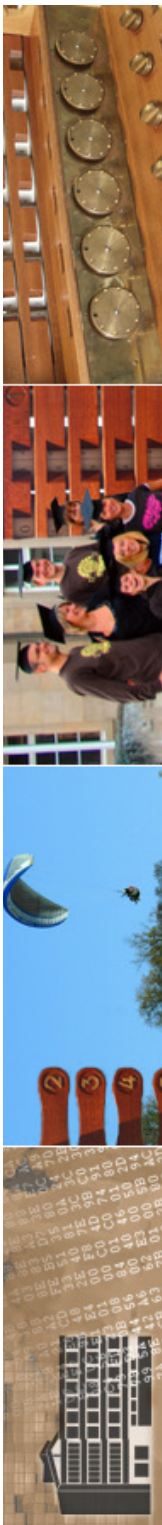

Hologon (1966)

- seltenes Spezial-Ultra-WW:
„A legend among camera objectives”

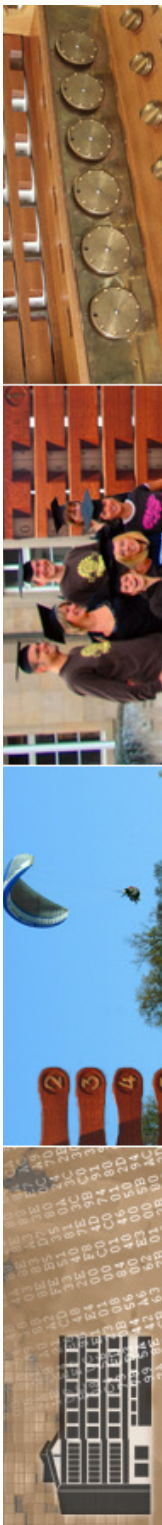
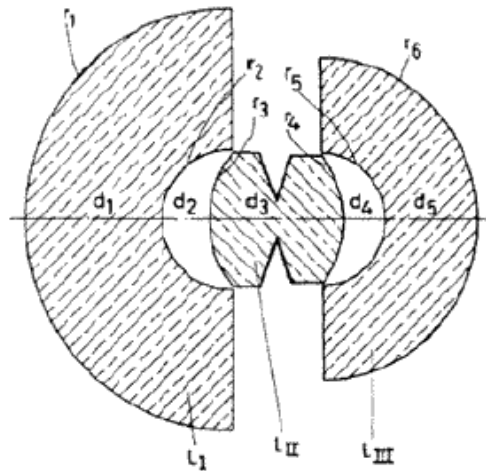
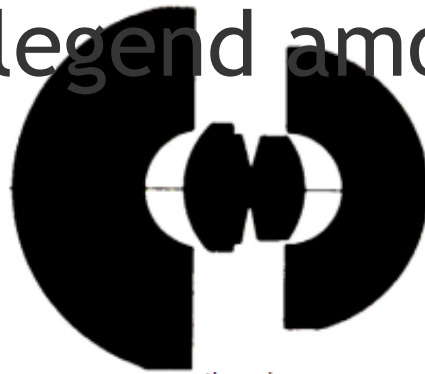

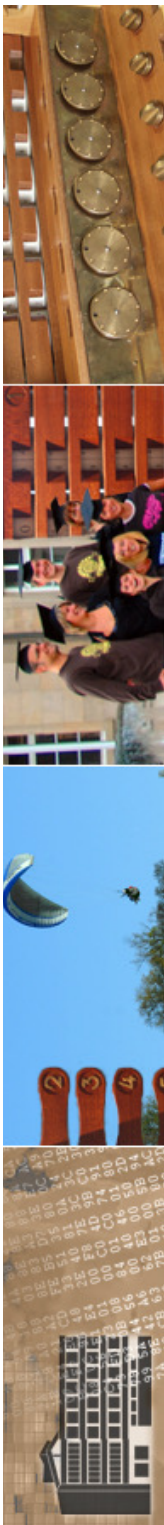

Hologon 2022

- ...wird möglicherweise neu nachgebaut

Zeiss Hologon 15mm f/8 lens prototype from Light Lens Lab

By LR ADMIN | Published: JULY 19, 2021

The Chinese company Light Lens Lab recently released a new 35mm f/2 lens for M-mount based on the original 8-element Leica 35 f/2 Summicron classic from 1958. It seems that their next project will be a remake of the Zeiss Hologon 15mm f/8 lens for Leica M-mount (see eBay listings):

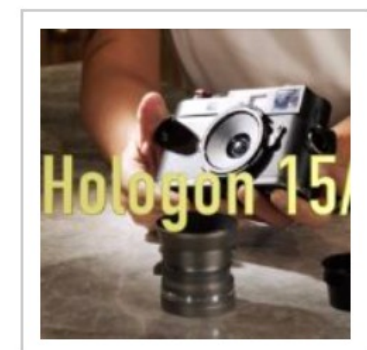

Posted in *Leica Lenses* | Also tagged *Light Lens Lab* | 14 Comments

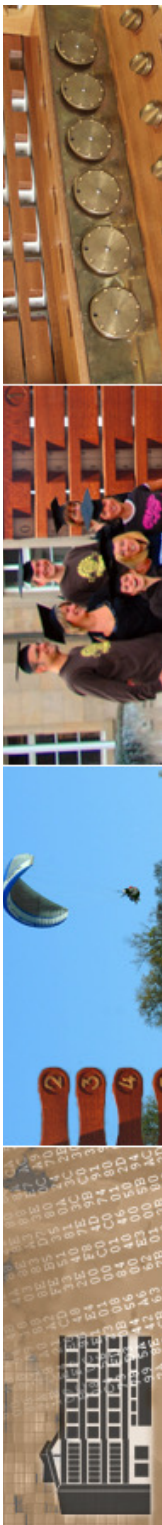

Ultra-WW und Portraits



...keine so gute Idee!

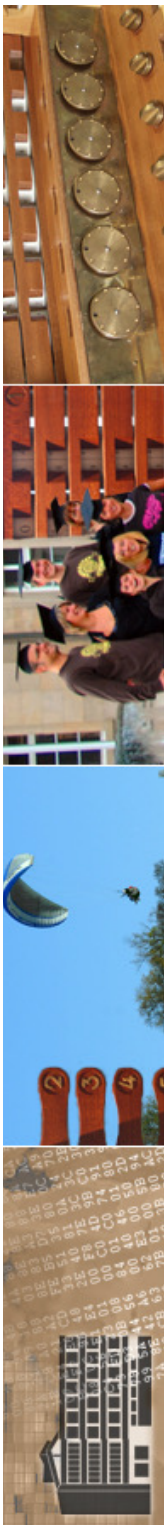



Zoom-Objektiv

- Objektiv variabler Brennweite
– wurde mal „Gummilinse“ genannt
- in der Regel damit auch *variable Lichtstärke*
- in der Regel sehr großer optischer Aufwand (> 15 Linsen)

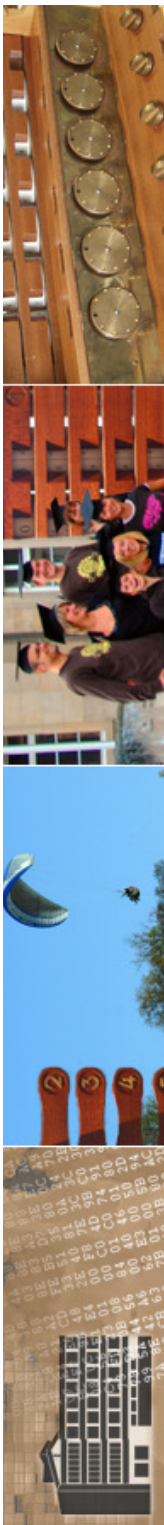

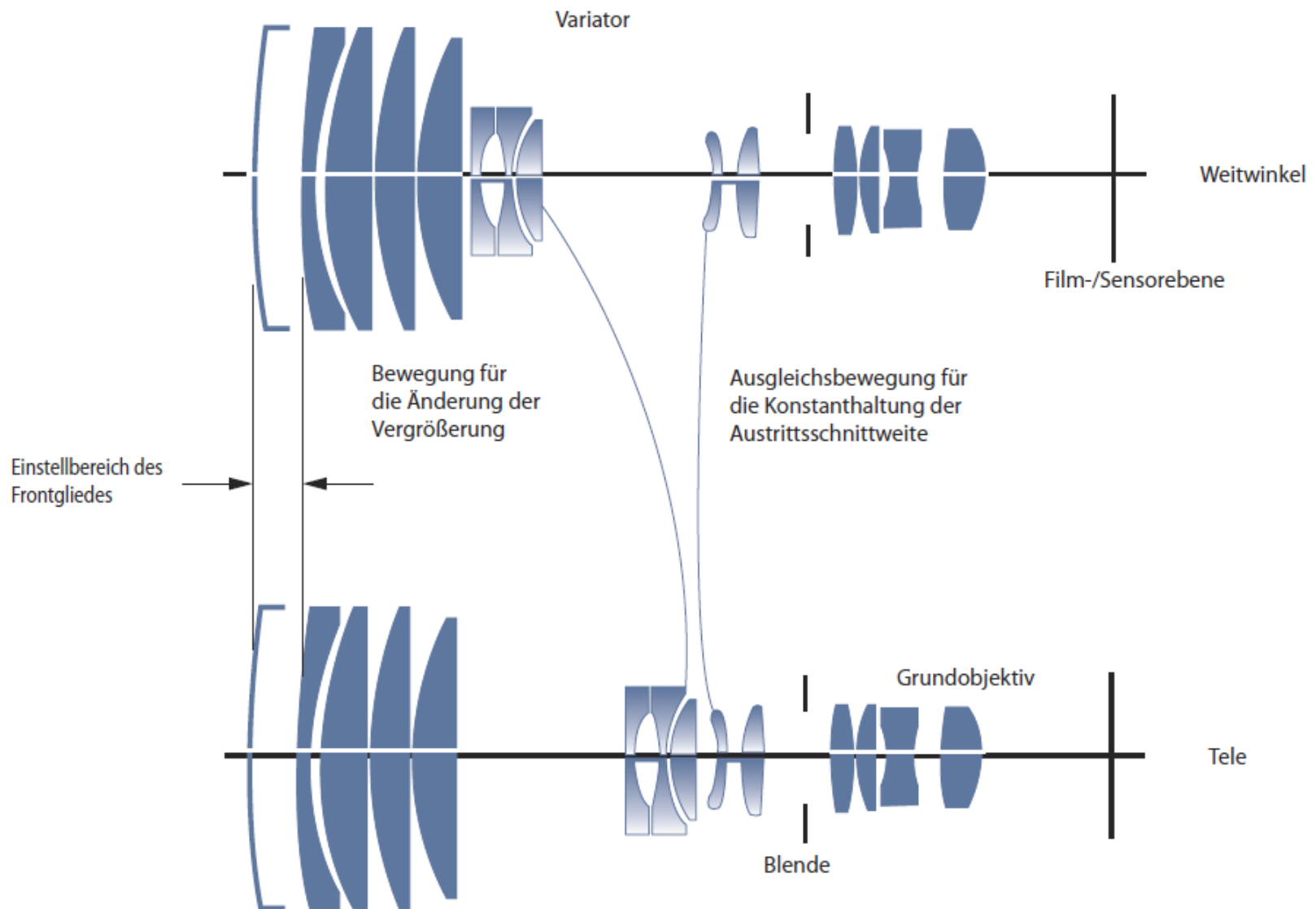
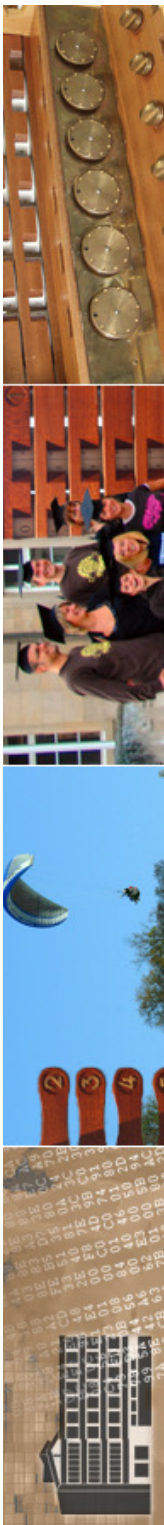

Zoom-Objektiv

- Beispiel 1 (24-90mm)
 - 18 Linsen in 15 Gruppen
 - 4 Asphären
 - 11 Sondergläser (anormale Teildisopersion)
 - Innenfokussierung
 - opt. Bildstabilisation

LINSENSCHNITT

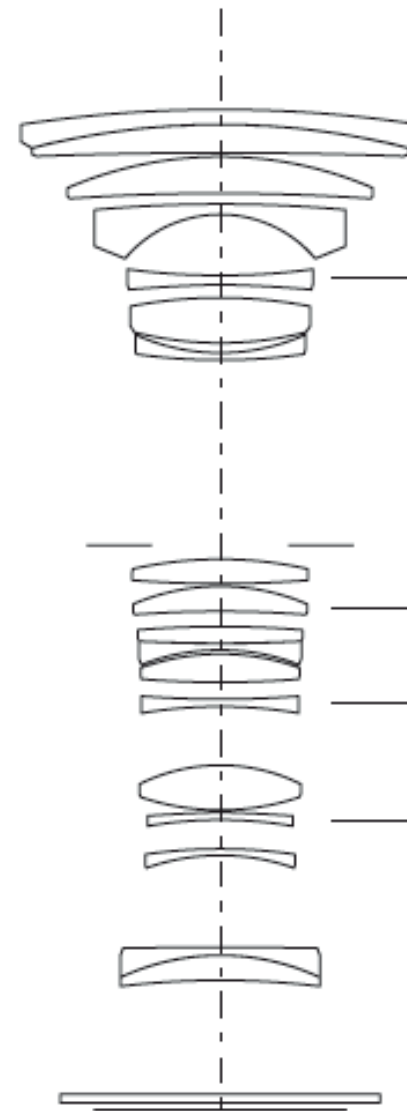

Asphärische Linsen



MTF-DIAGRAMME

Unendlich (∞)

Brennweite 24 mm

Brennweite 50 mm

Brennweite 90 mm

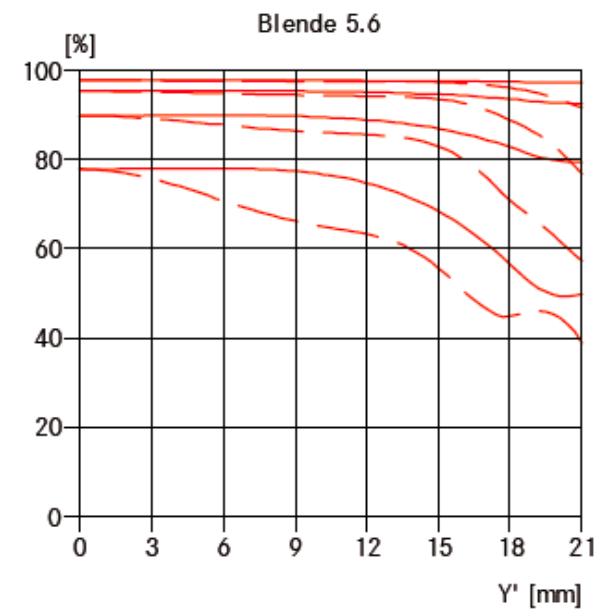
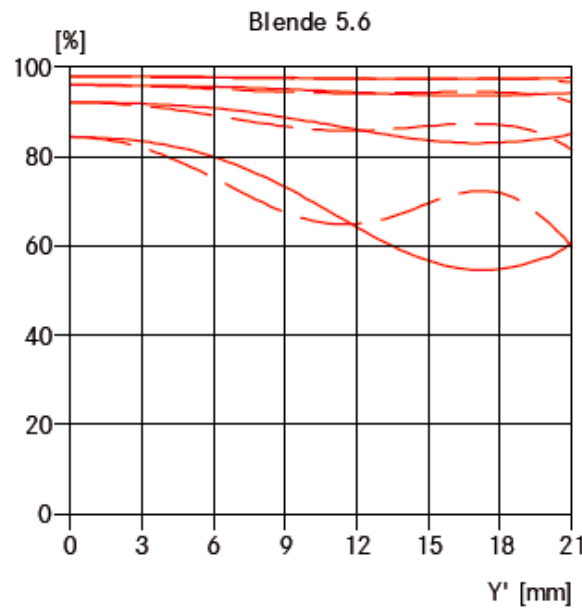
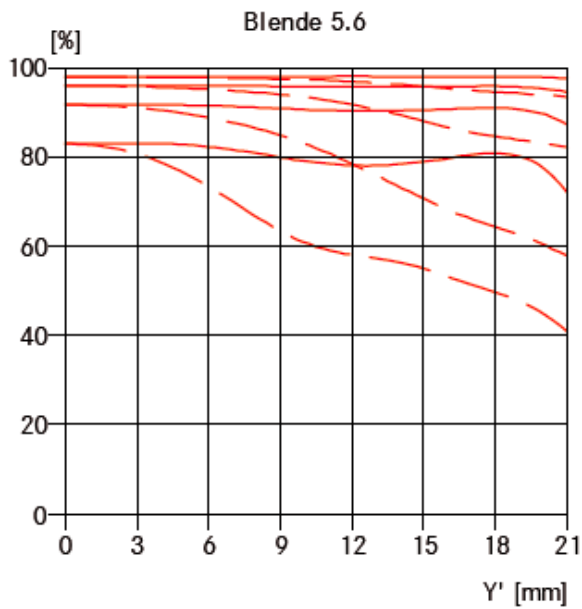
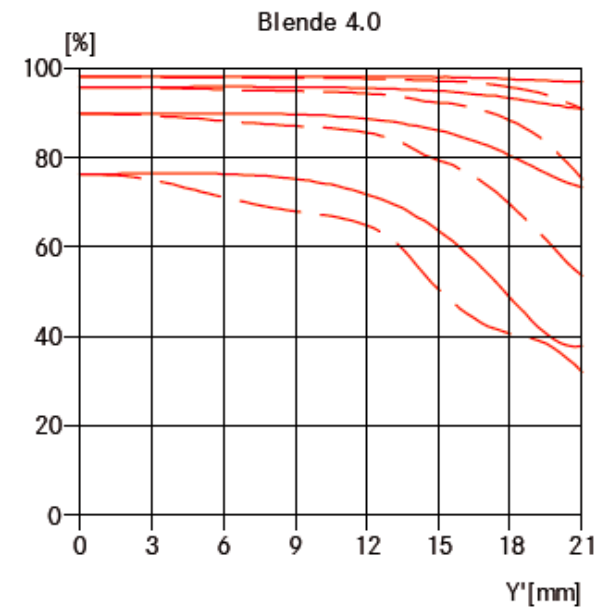
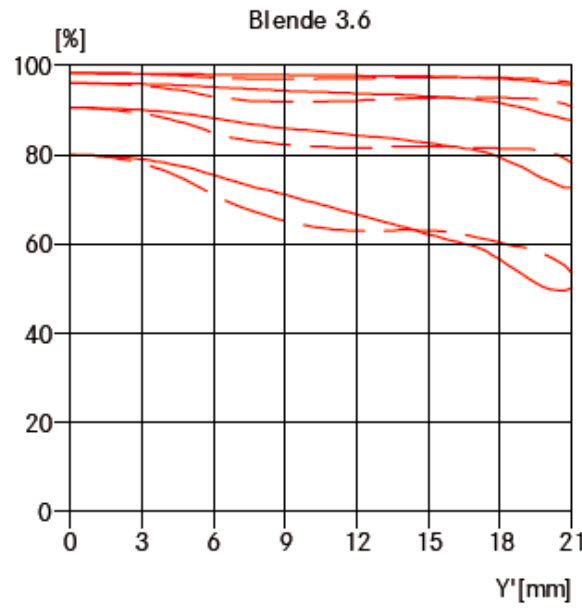
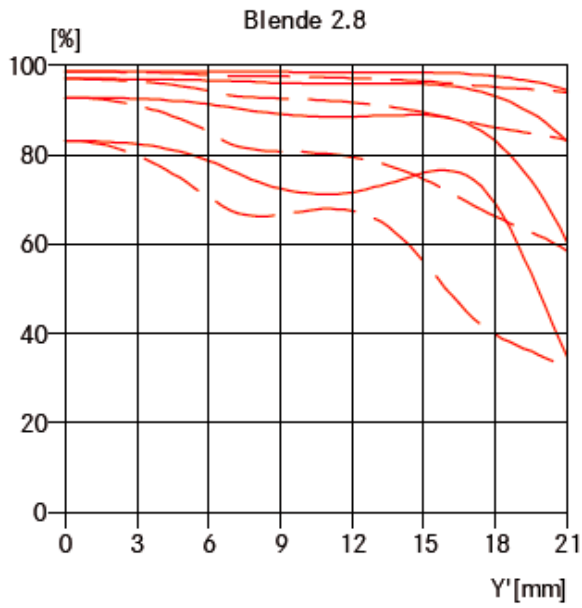

Zoom-Objektiv

- Beispiel 2 (90-280mm)
 - 23 Linsen in
17 Gruppen
 - 4 Sondergläser
(anormale
Teildisopersion)
 - Innenfokussierung
 - opt. Bildstabilisation

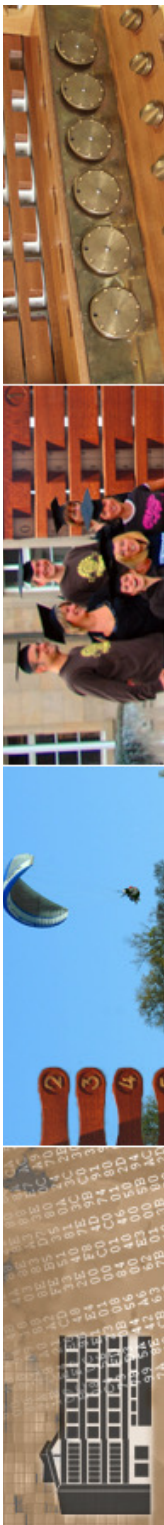
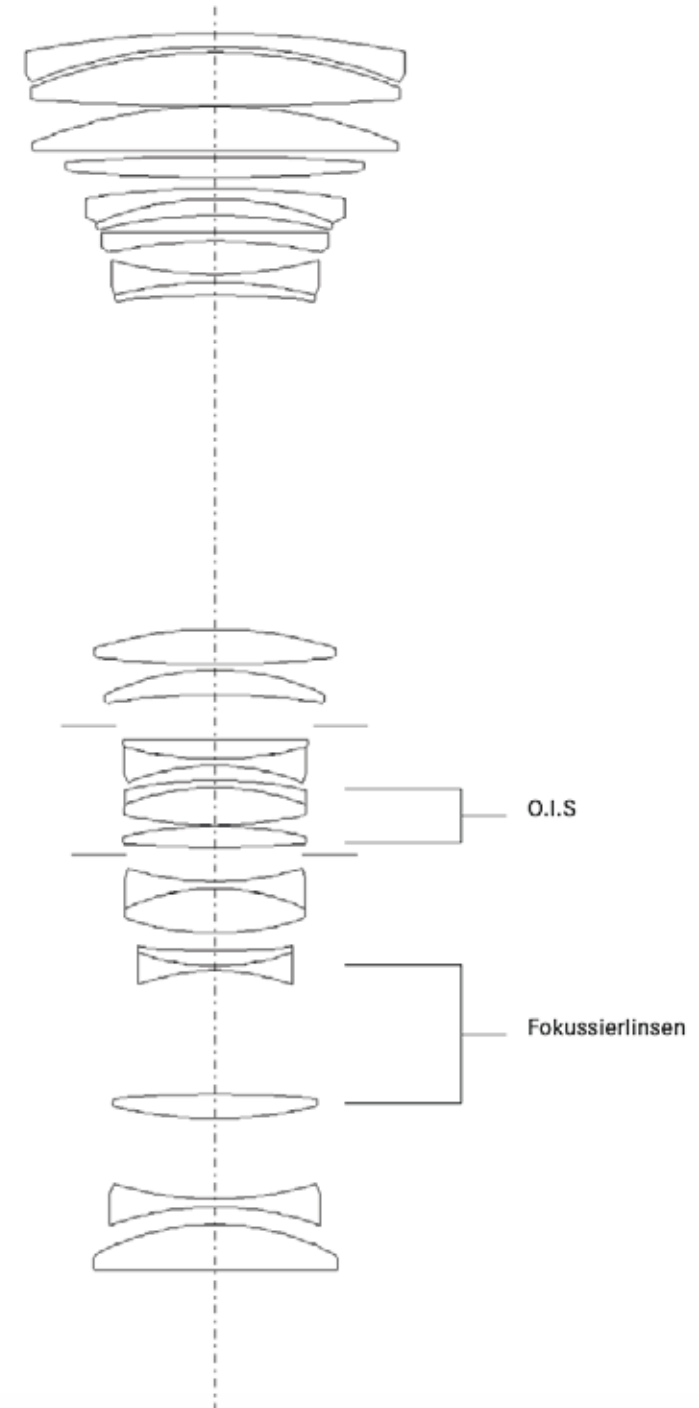



Brennweite 90 mm

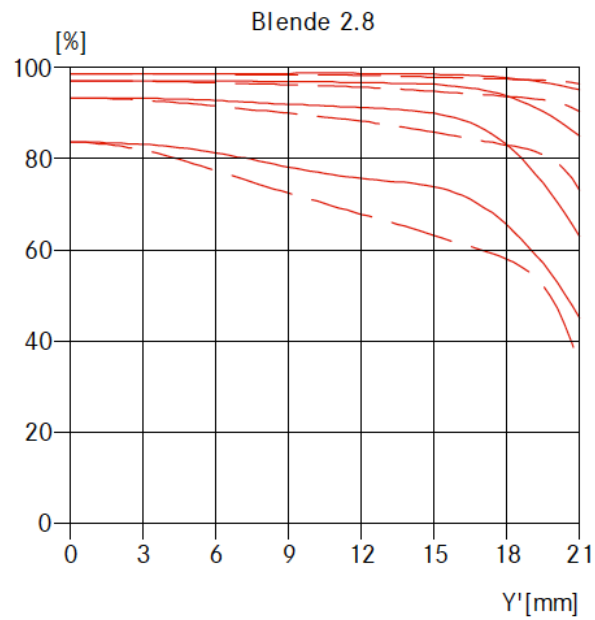

Brennweite 160 mm

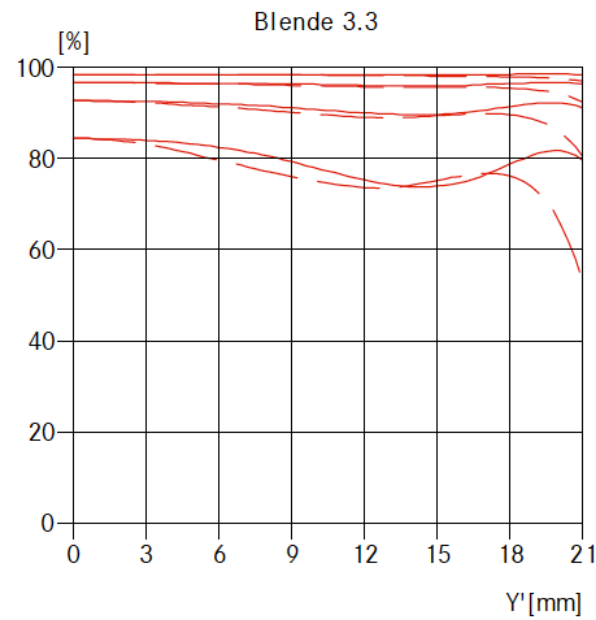

Brennweite 280 mm

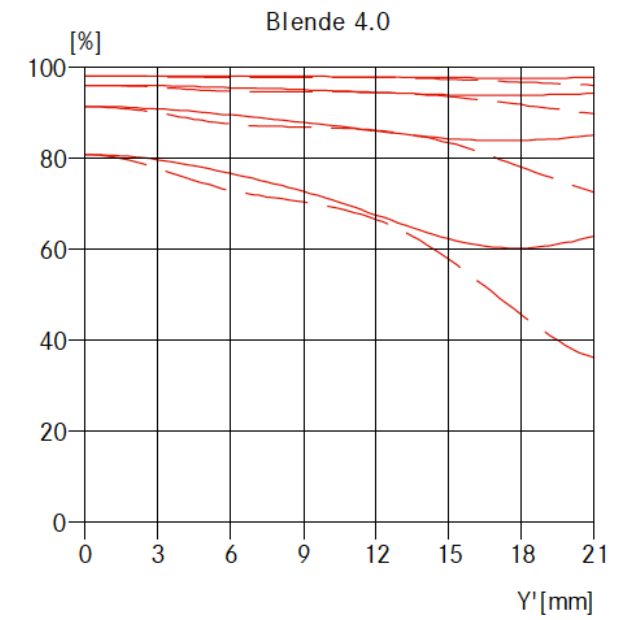

Blende 5.6

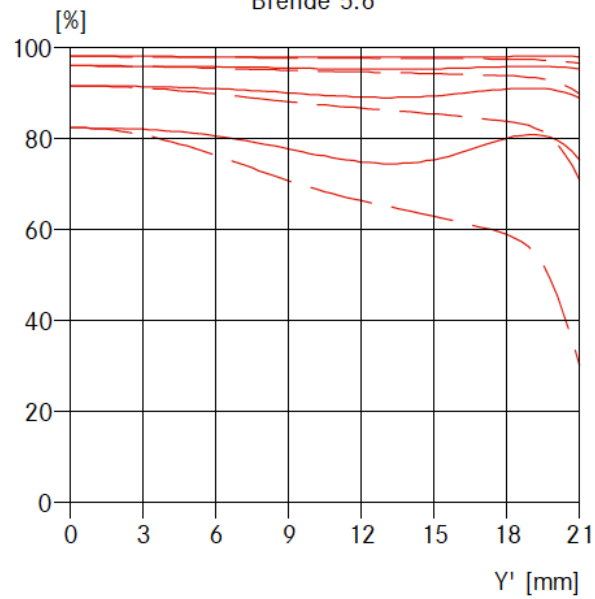

Blende 5.6

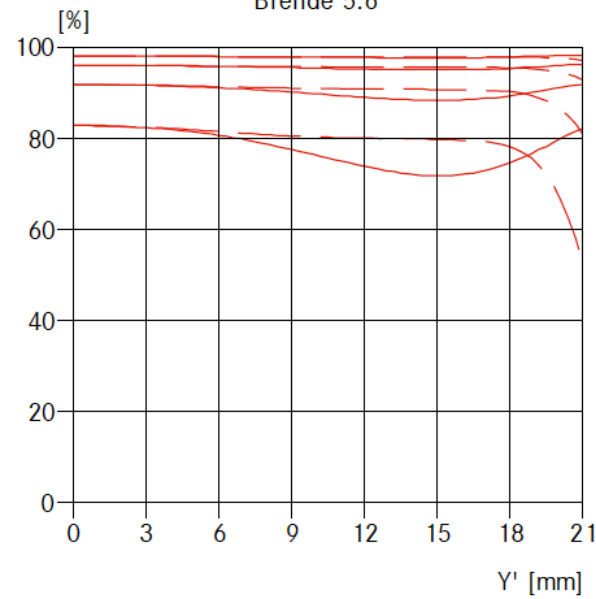

Blende 5.6

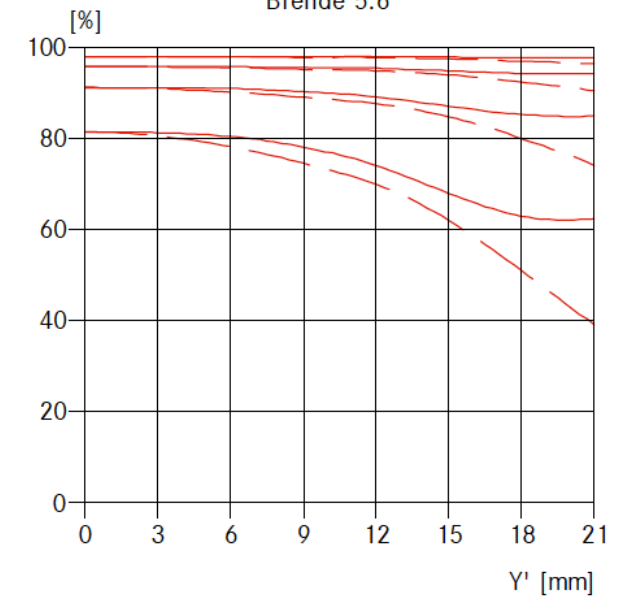



Nikkor Z 24-70/4 S



Lens Construction

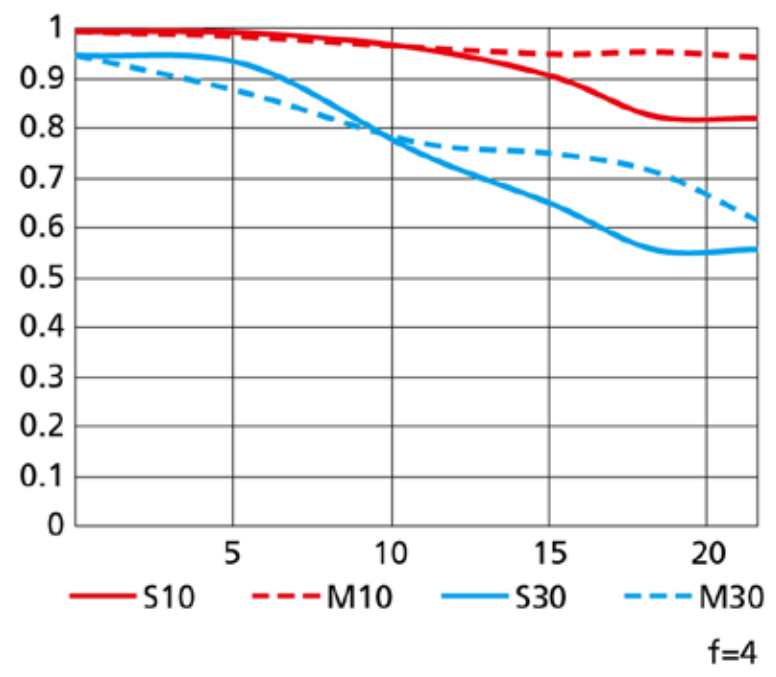
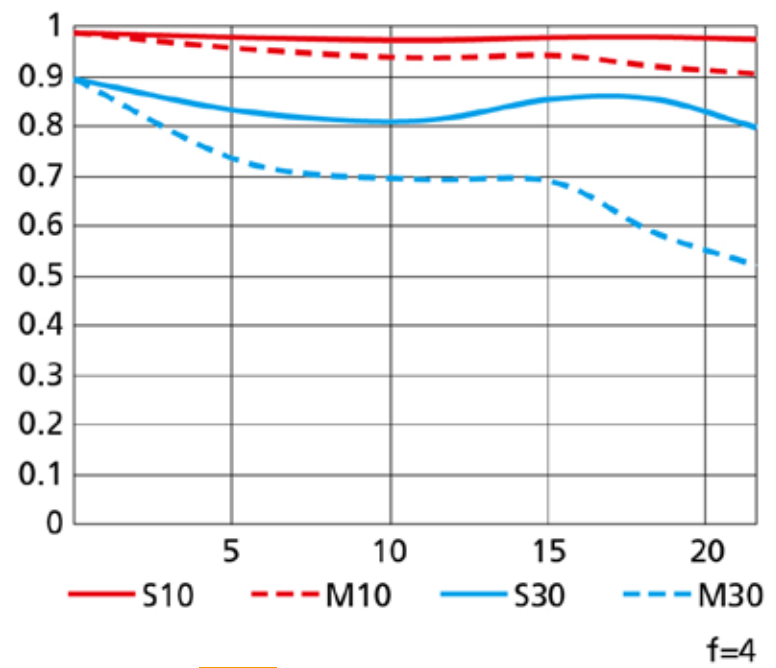
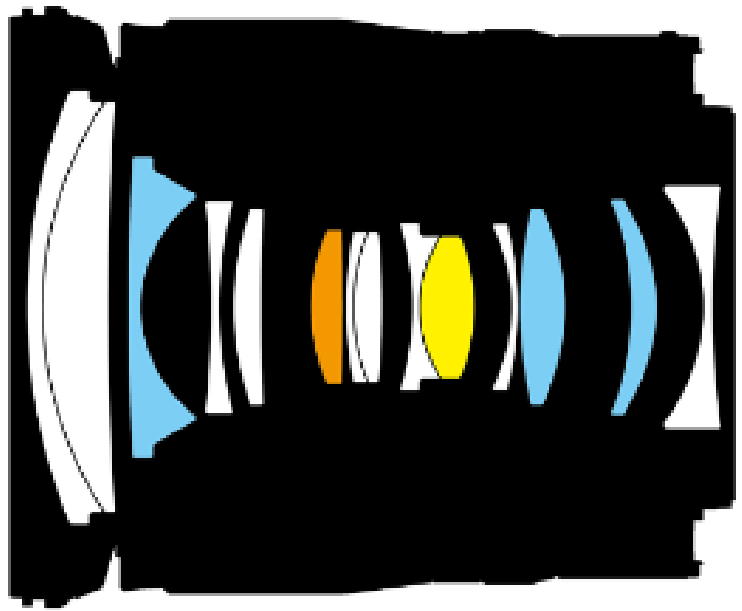

ment

S

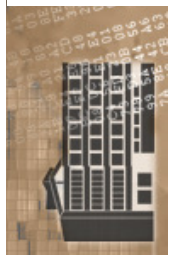

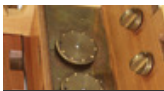

Canon RF 28-70mm F2L USM

Technische Daten

Seite nach Kategorie

Filterdurchmesser (mm)

95

Max. Durchmesser x Länge (mm)

103,8 x 139,8

Gewicht (ca. g)

1.430

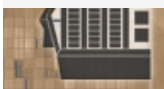

die „heilige Trinität“

- ...sind bei den großen Herstellern die hochwertigen Zooms Lichtstärke 2,8

- 14-24mm/2.8
- 24-70mm/2.8
- 70-200mm/2.8

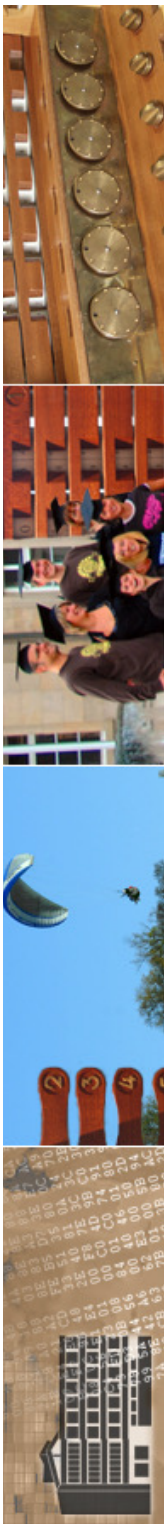
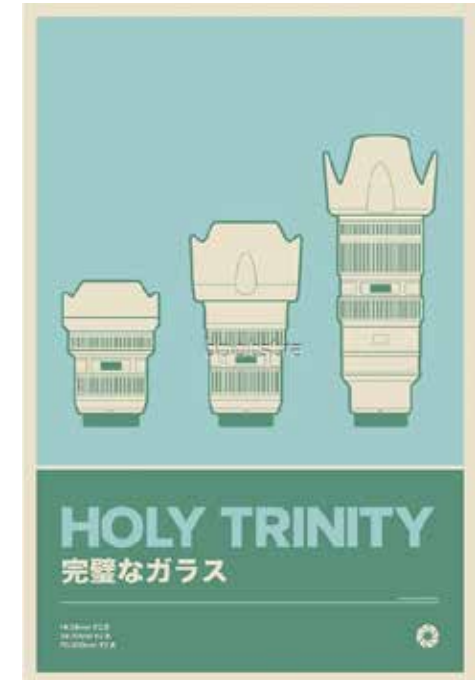



NIKKOR TRIPLE F2.8 ZOOM LENS-SET-KIT – JUBILÄUMSEDITION ZUM 100-JÄHRIGEN BESTEHEN

NIKKOR-Objektive sind zu einem Synonym für die optischen Technologien von Nikon geworden. Dieses Jubiläums-Set umfasst die drei Zoomobjektive mit Lichtstärke 1:2,8, die den Namen NIKKOR am besten repräsentieren: das Weitwinkelobjektiv AF-S NIKKOR 14–24 mm 1:2,8G ED, das AF-S NIKKOR 24–70 mm 1:2,8E ED VR mit normalem Bildwinkel und das Teleobjektiv AF-S NIKKOR 70–200 mm 1:2,8E FL ED VR. In alle drei Objektive ist die gleiche Jubiläums-Seriennummer eingraviert.





RF lenses - The Trinity

The three essential fast aperture, high performance RF L-series lenses with image stabilization

[Overview](#) [Gallery](#) [Support](#)

Every Professional assignment covered

Three RF lenses covering ultra-wide, standard, and telephoto zoom ranges, for shooting in practically any situation from landscapes, portraits and sports, to interiors, fashion and cityscapes.



RF LENSES

Canon RF 15-35MM F2.8L IS USM

Ultra-wide and super sharp thanks to L-series optical quality and 5-stop image stabilisation for dynamic angles even in tight spaces



RF LENSES

Canon RF 24-70MM F2.8L IS USM

Give your full frame mirrorless photography the professional edge with a 24-70mm zoom boasting a fast aperture, 5-stops of image stabilisation and silent Nano USM AF motor.



RF LENSES

Canon RF 70-200mm F2.8L IS USM

A must-have super compact high speed telephoto lens for any professional photographer shooting weddings, sport or wildlife.

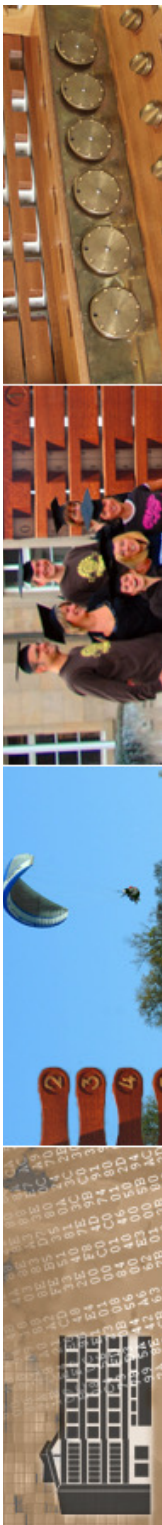



Sony's New Holy Trinity

THE NEW HOLY TRINITY



Sony FE 12-24mm f/2.8 GM, FE 24-70mm f/2.8 GM & FE 70-200mm f/2.8 GM OSS Lenses

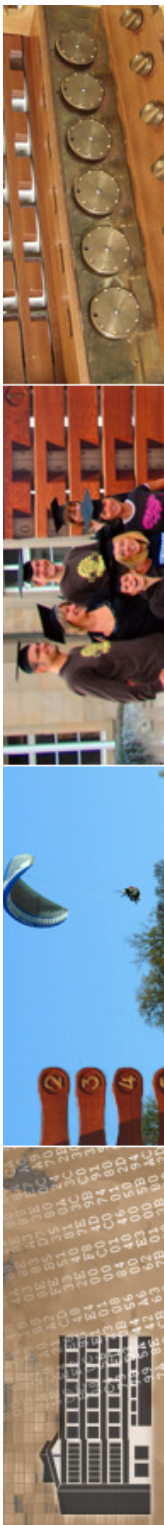

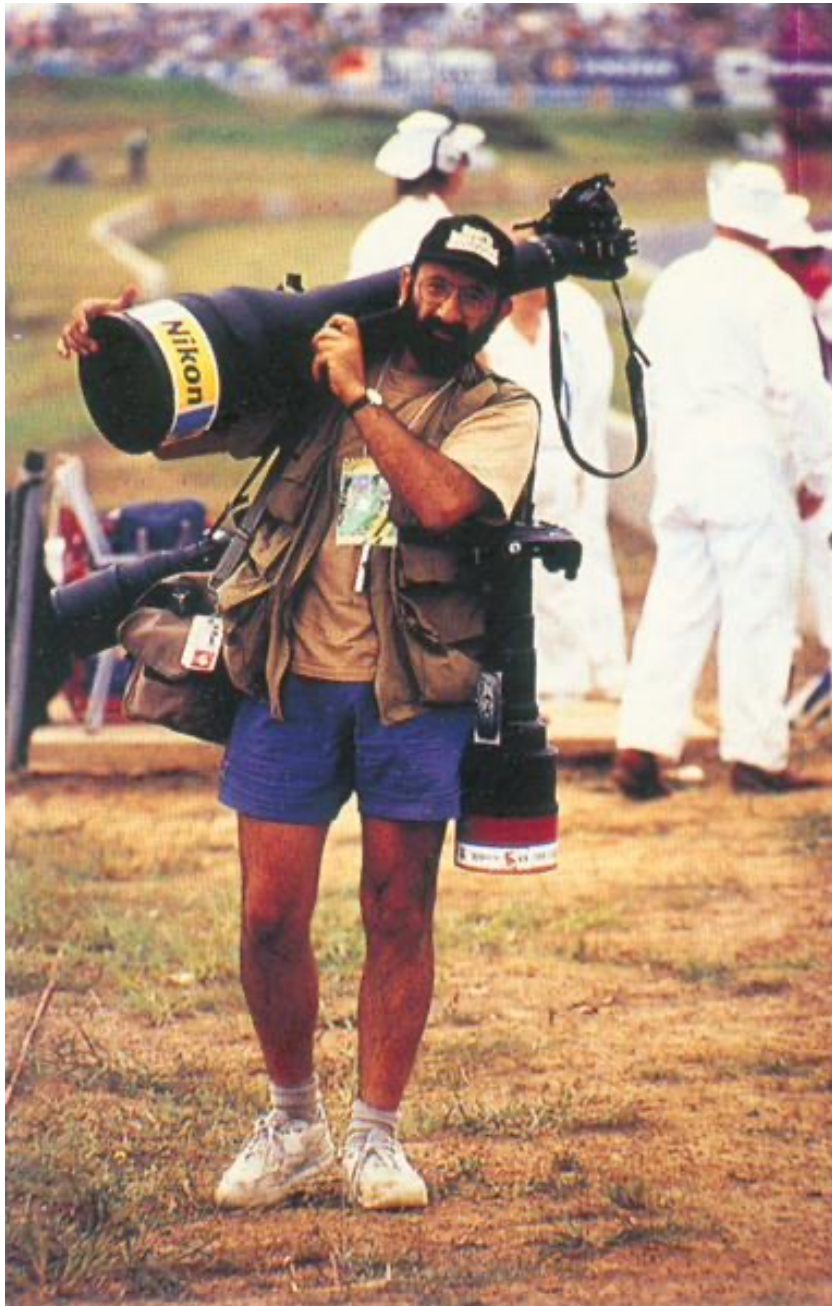

Telezoom
1.200mm -
1.700 mm
5.6-8.0

16kg

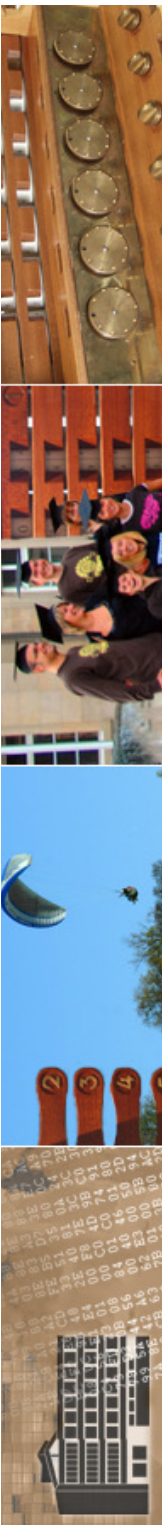



Nikon ED Nikkor 1200-1700mm f/5.6-8 P IF lens at the next Wetzlar Camera Auctions (October 07)

By [NR] ADMIN | Published: OCTOBER 4, 2023



The upcoming [Wetzlar Camera Auctions](#) on October 07, will auction a Nikon ED Nikkor 1200-1700mm f/5.6-8 P IF lens. In 1996 Nikon offered the longest focal length of any zoom lens available for the 35mm format. A prototype was first used in 1990 at the Koshien Stadium in Amagasaki. After that, Nikon delivered these lenses to news agencies worldwide. Beginning in 1994 Nikon made this massive lens available to the general public on a build-to-order basis – presumably no more than 35 units were produced in total worldwide.

Estimated price: 80,000 – 100,000 euros.



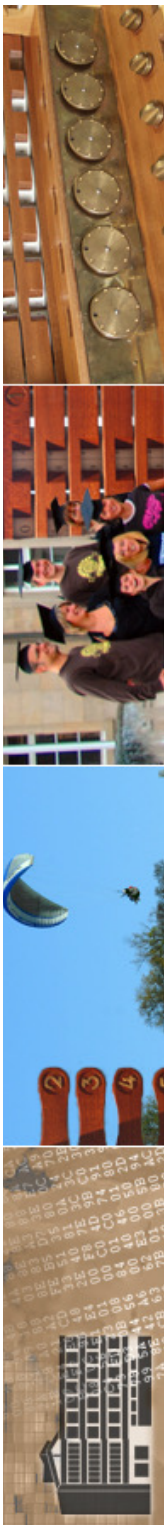

Tele,
aber
kein
Zoom

16,5kg

© 2023 Universität
Tübingen

CANON•OBJEKTIVE

Canon Objektiv zum Rekordpreis von 500.000 € verkauft

Mark Göpferich · 19. Oktober 2021 · 28 Kommentare



Bei der Wetzlar Camera Auctions wurde ein Canon 1200mm f/5.6 für 500.000 € verkauft. Ein solcher Preis wurde für ein Objektiv noch nie erzielt.

Rekordpreise bei Auktionen

Wenn Kameras oder Objektive nur in einer sehr geringen Stückzahl existieren und vom Hersteller schon seit langer Zeit nicht mehr produziert werden, dann kann das unter Umständen für hohe Preise sorgen – sehr hohe Preise sogar. Im vergangenen August wurde beispielsweise eine außergewöhnliche schwarze Leica IIIg bei der 38. Leitz Photographica Auction zum Preis von 408.000 Euro verkauft, obwohl der damalige Besitzer sie lediglich zwei Jahre zuvor für 20.000 Euro erworben hatte.

Makro

- Makro-Objektive sind nicht auf eine Fokussierung auf unendlich optimiert, sondern auf eine Fokussierung im Nahbereich (typisch 1 Meter)

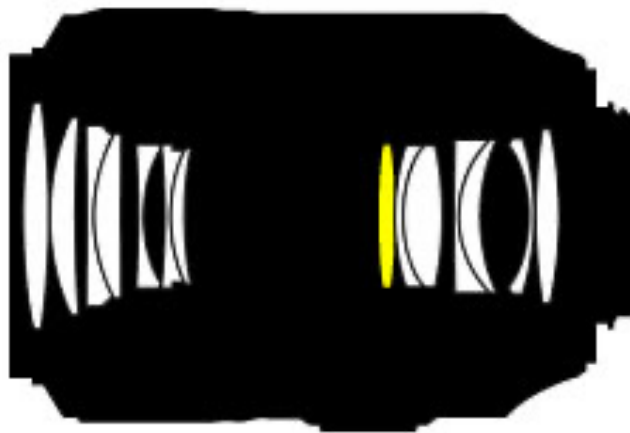

Nikon Makro AF-S 105/2,8

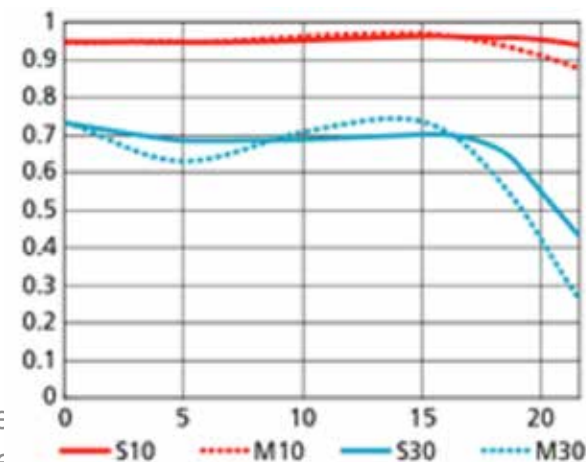



<https://www.heise.de/ratgeber/Makrofotografie-Maximale-Bildqualitaet-wunderschoenes-Bokeh-So-geht-s-7331556.html>



Nikon Z MC 105mm/2.8

Lens Construction

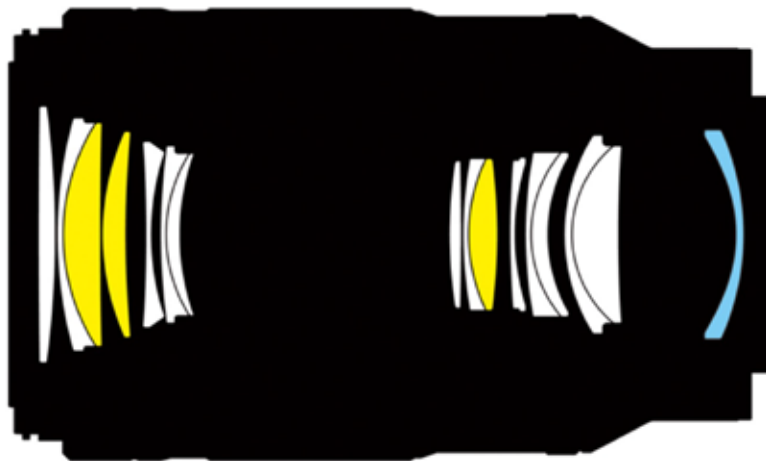

MTF Chart

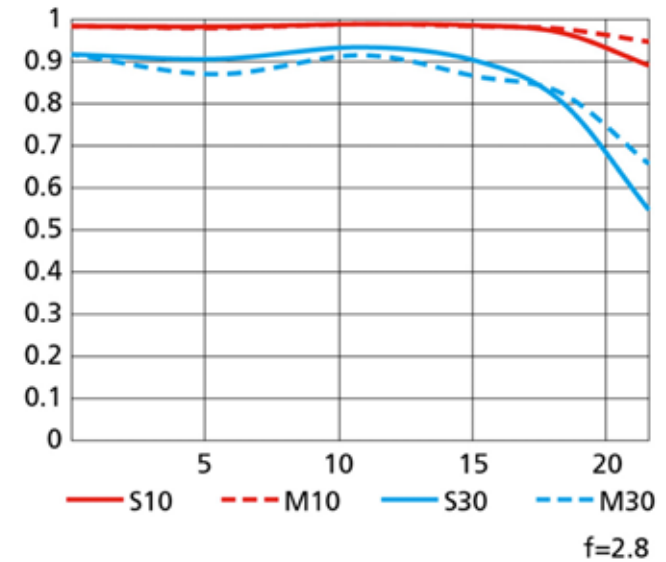

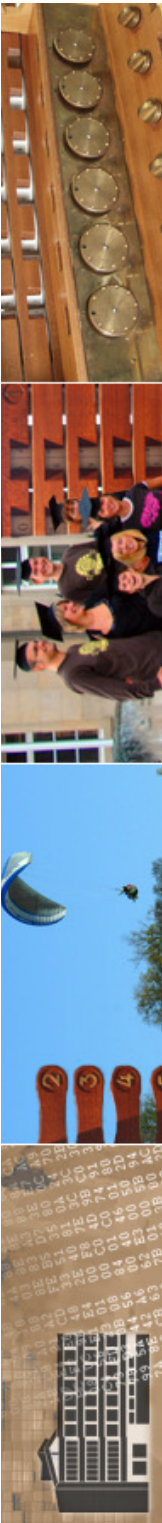

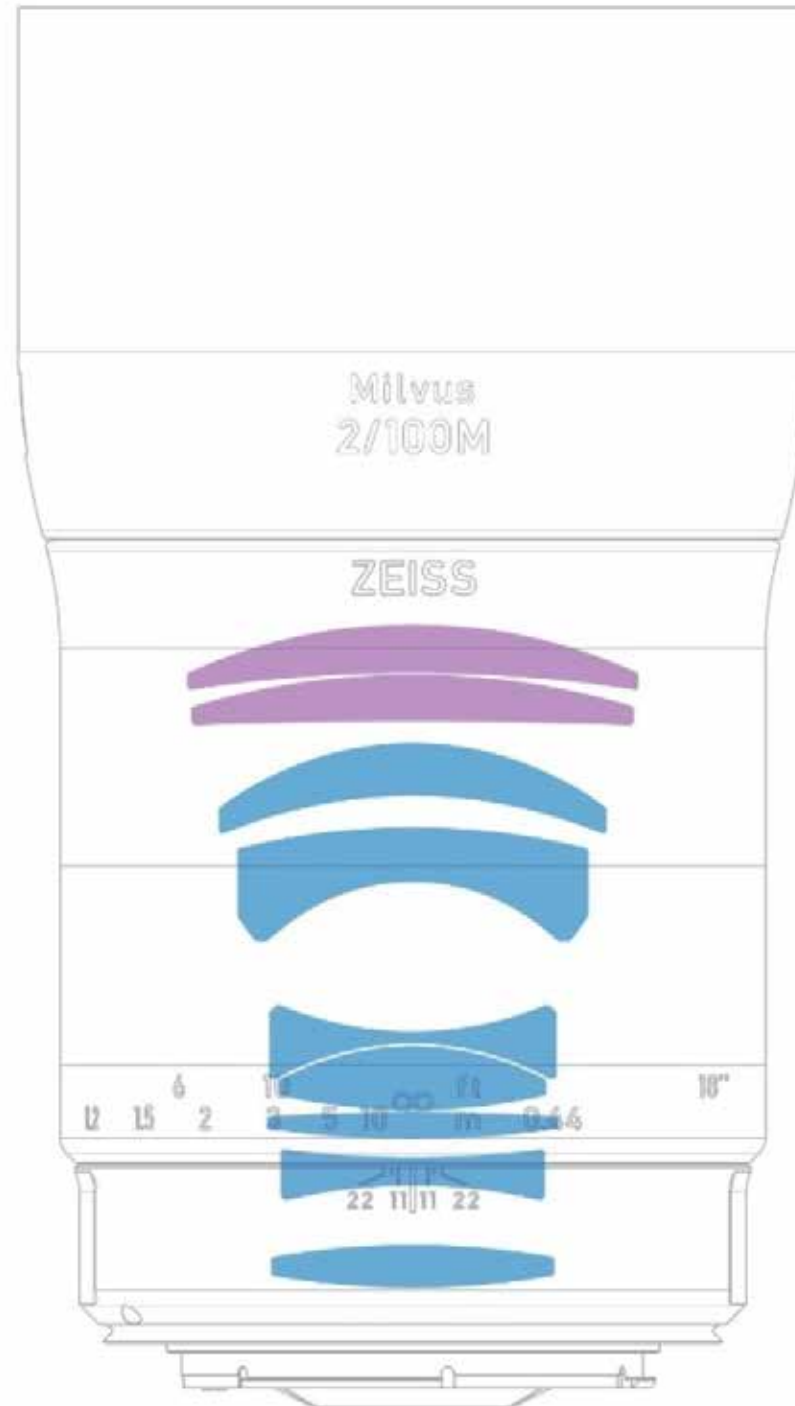
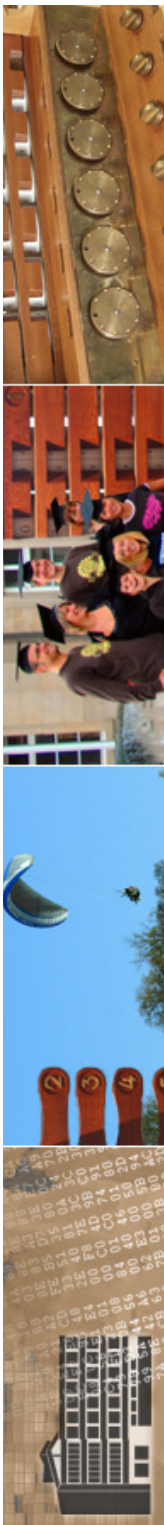

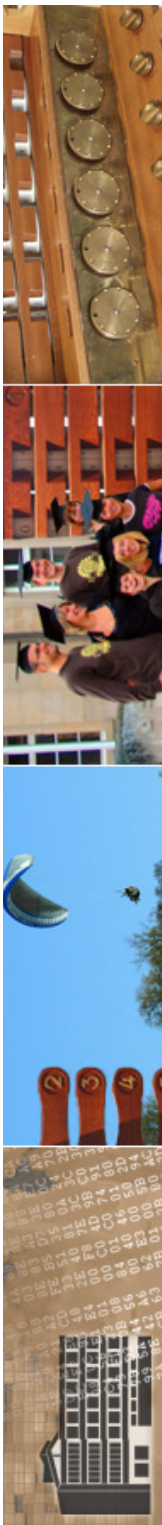

Sigma Macro 105/2,8 DG DN

Objektivkonstruktion

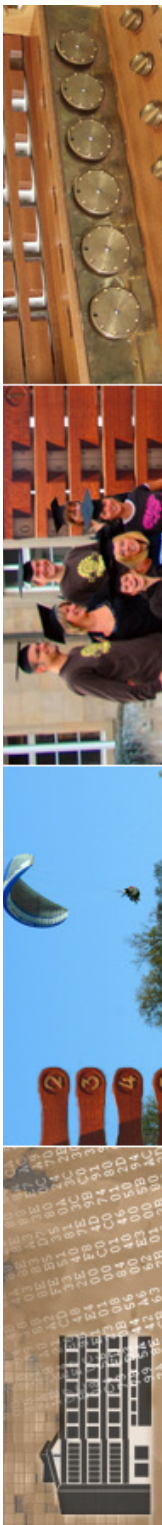
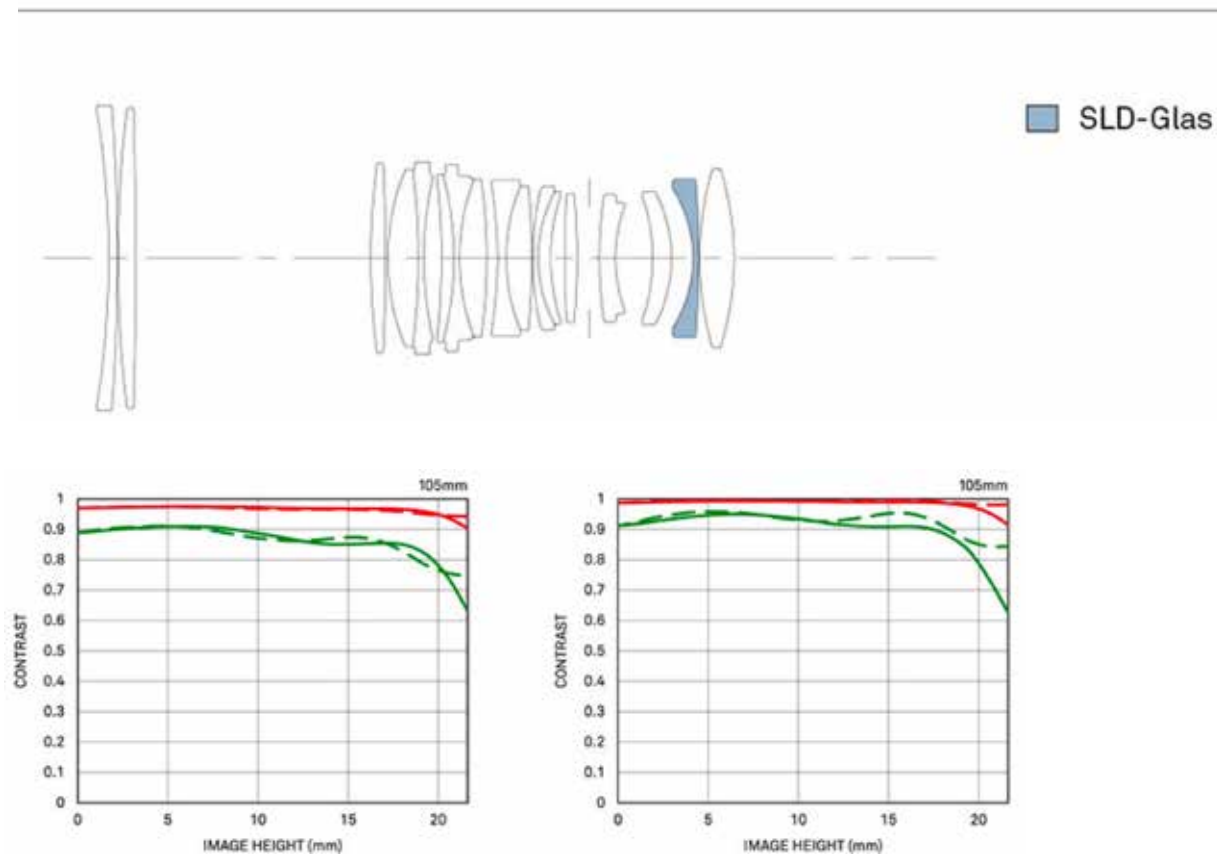

Sigma 105mm F2,8 Macro DG DN Art

Objektivkonstruktion

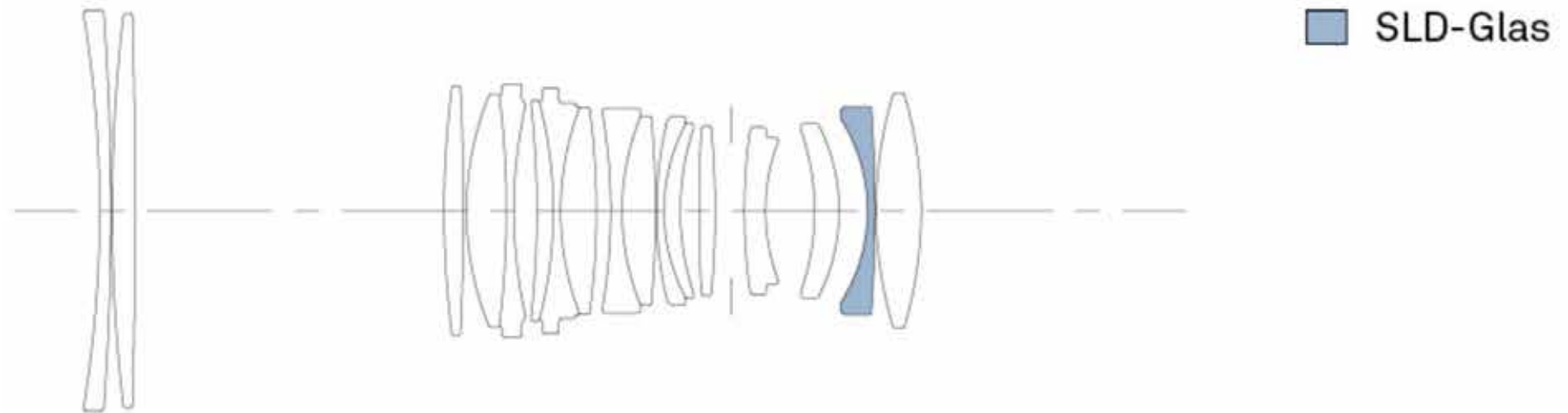

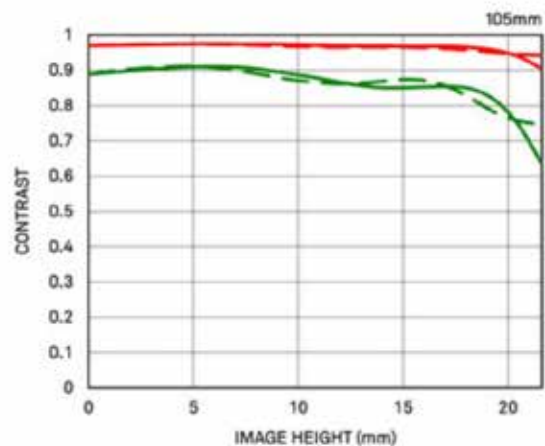
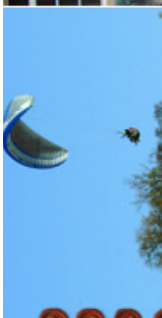

MTF Beugung 105mm F2,8 DG DN MACRO | Art

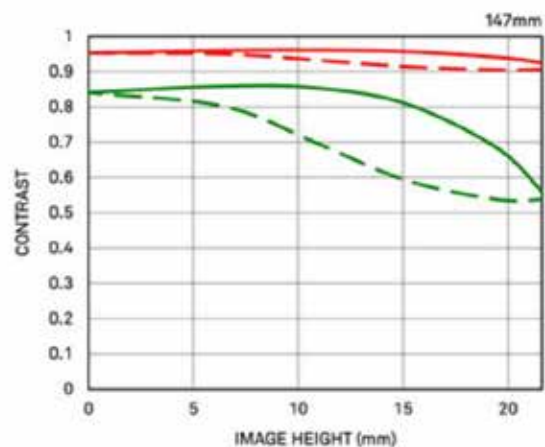

MTF Beugung 105mm F2,8 DG DN MACRO | Art + TC-1411

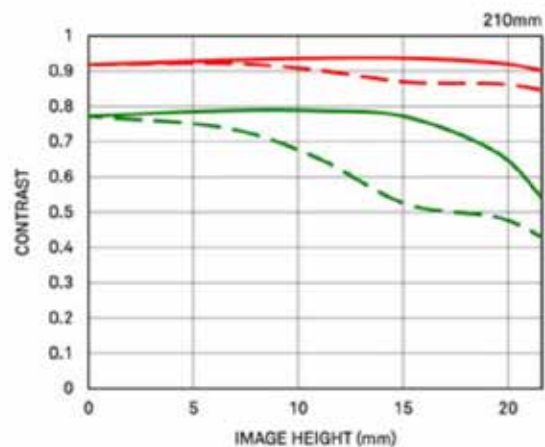

© Tü MTF Beugung 105mm F2,8 DG DN MACRO | Art + TC-2011

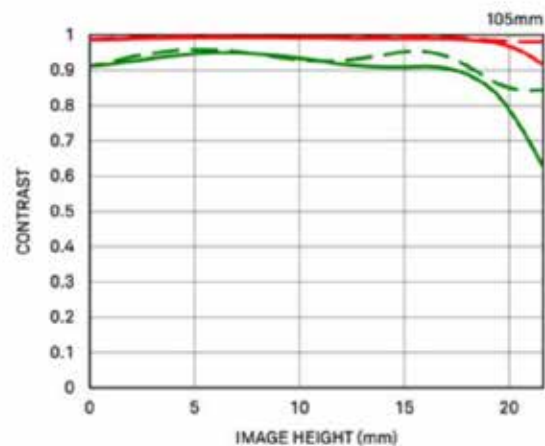

MTF Geometrisch 105mm F2,8 DG DN MACRO | Art

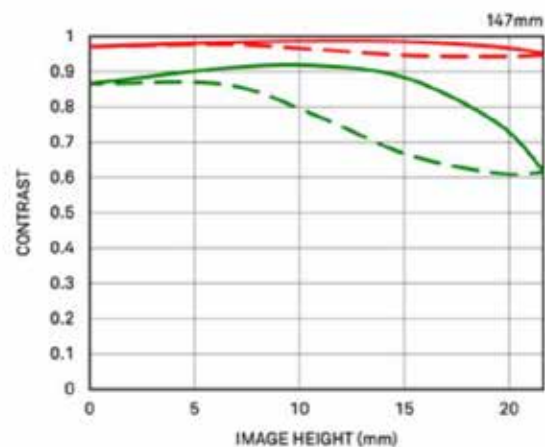

MTF Geometrisch 105mm F2,8 DG DN MACRO | Art + TC-1411

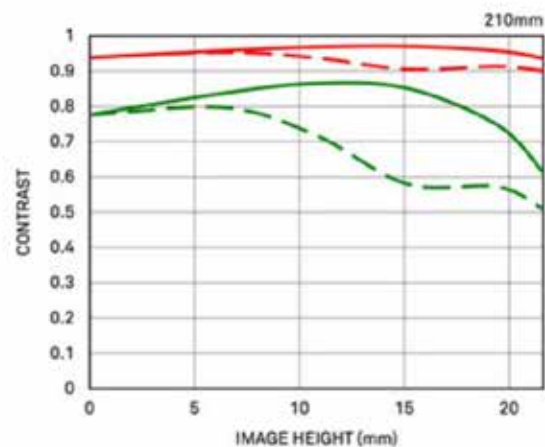

MTF Geometrisch 105mm F2,8 DG DN MACRO | Art + TC-2011

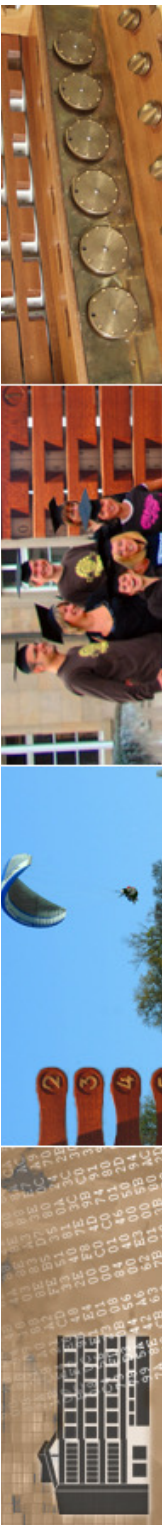

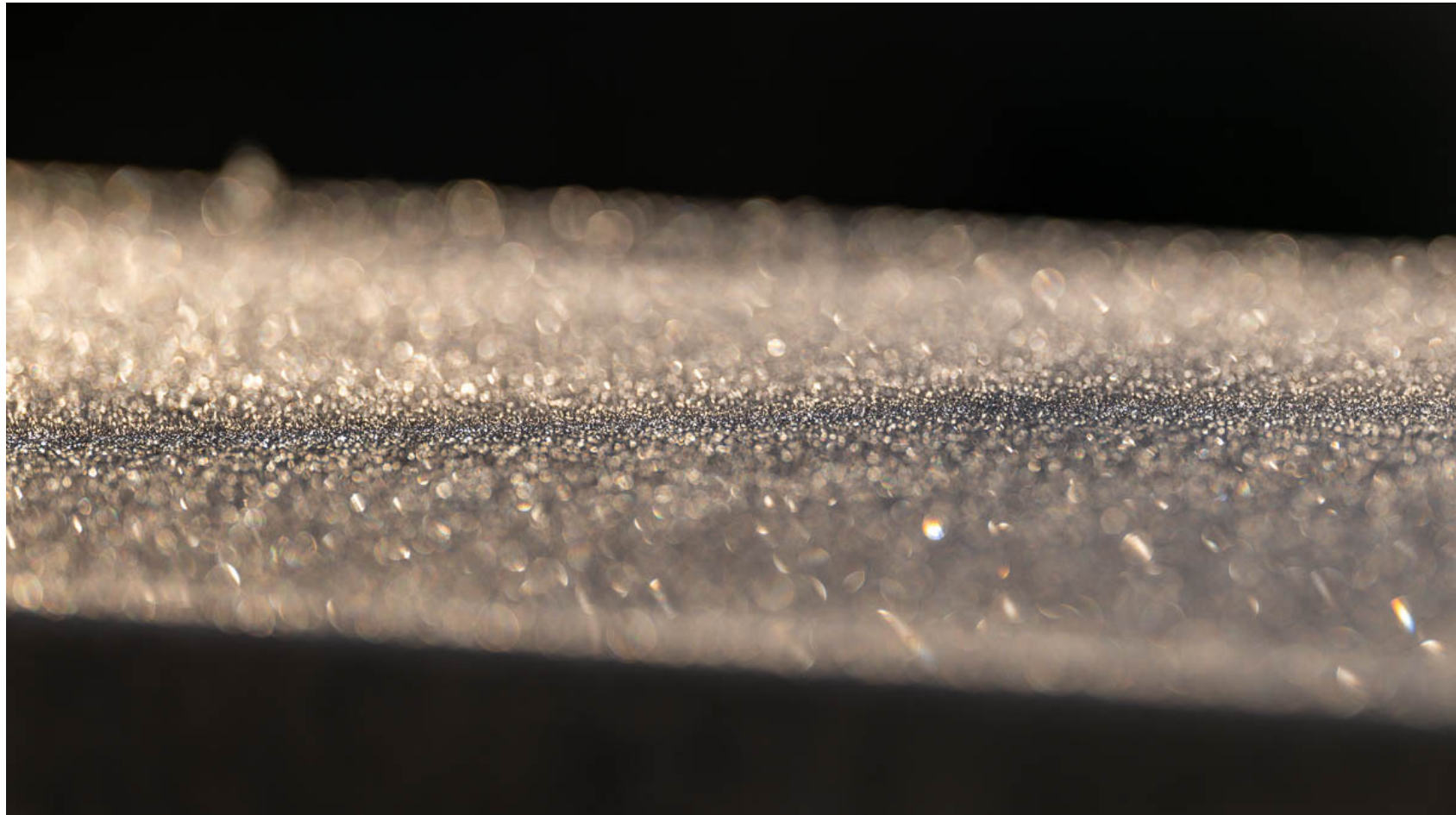
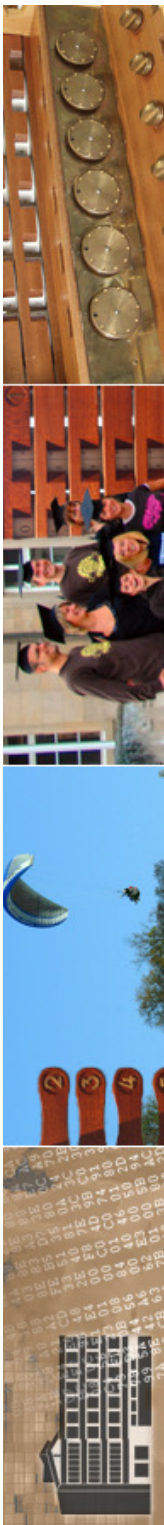

„Makro-Extrem“: Balgengerät

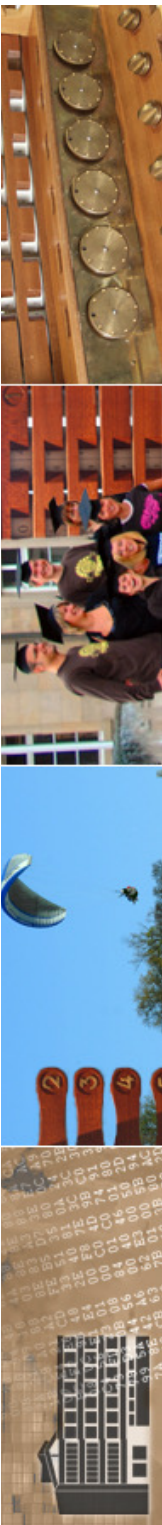



Master Technika classic

Linhof Kamera, Technika

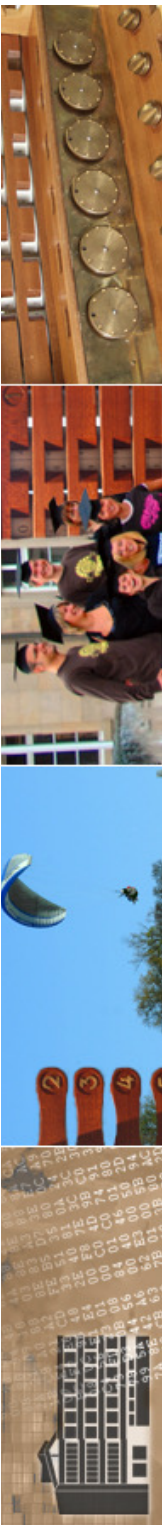

Fisheye

- **sphärische Abbildung**
(orthografische
Projektion)

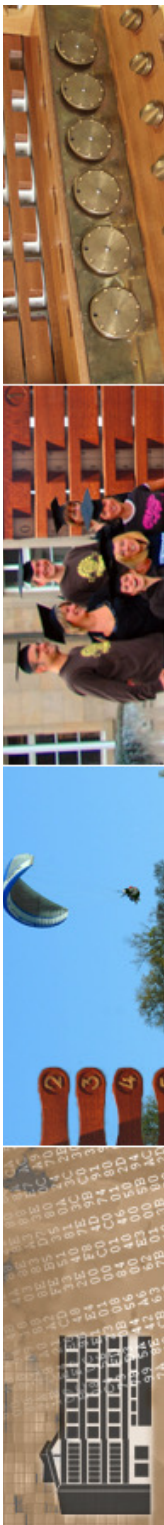
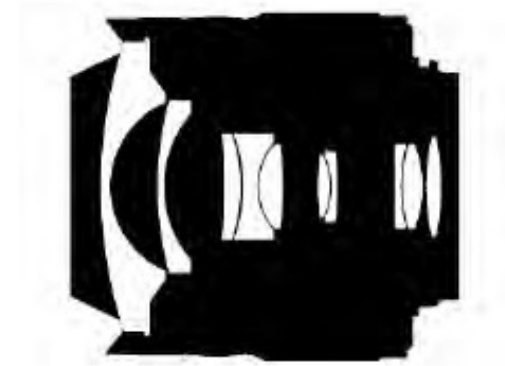

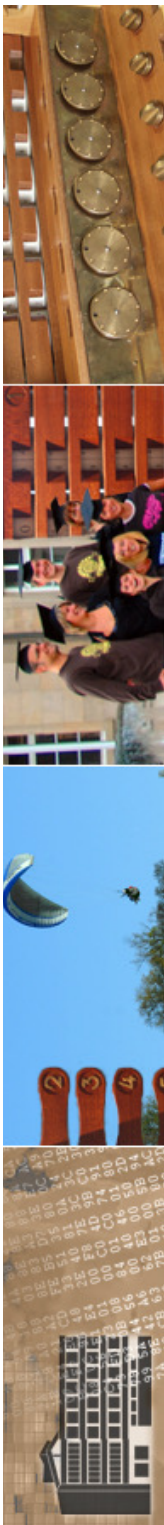

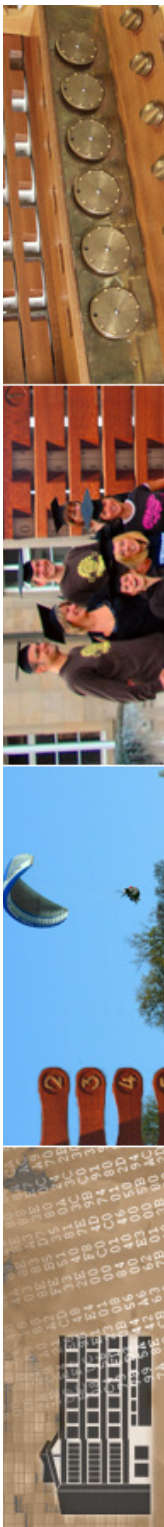

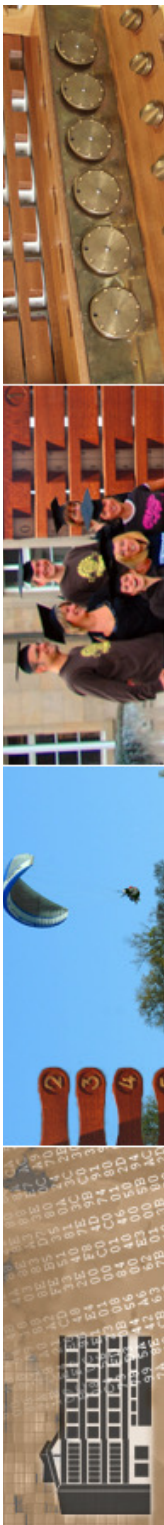



DSC_6827.NEF* @ 25% | 32,2MB



Übersicht

Bildversion

Schnellanpassung

Schnellanpassung

Eingabe:

Belichtungskorrektur
-2

Kontrast
-100

Lichter
▲

Schatten
▲

Farbsättigung
-100

Kamera- und Objektiv

Farbmoiré-Reduzieren
Aus

Staubentfernung
Neuer Schritt

Histogramm
RGB

Start

Messpunkte

Open sRGB 4.0.0.3002 Digitalproof aus



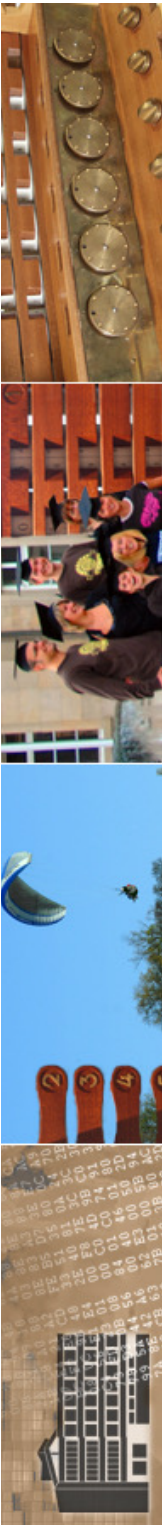



Fisheye photo © 2006 Jarle Aasland
Nikkor 6mm mounted on Nikon F3 body © 2006 Kazuo Koga



- ## Nikon 6mm/2.8 Fisheye
- 220 Grad Bildwinkel
 - 5,2 kg

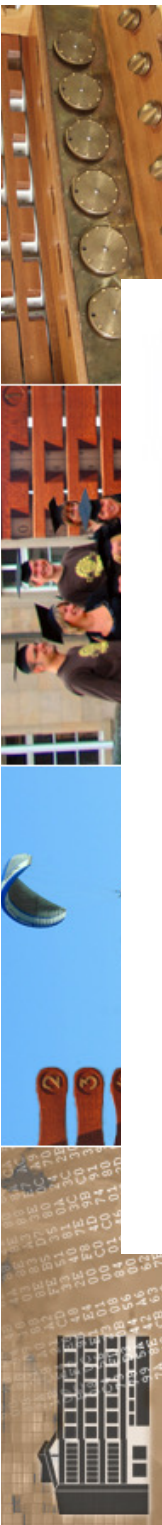

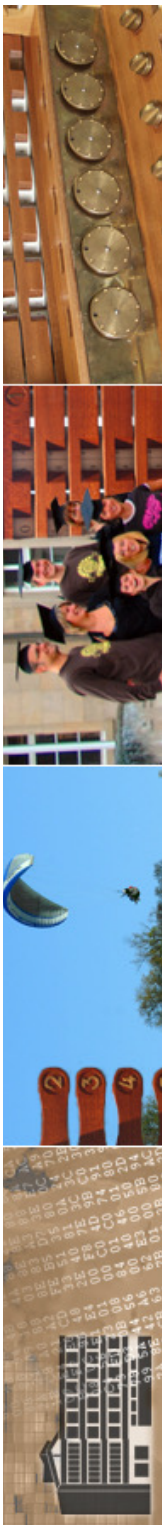

Die Linse, die nach hinten schaut

Das Nikkor 6mm f/2.8 Fisheye zählt zu den Legenden der Kleinbildfotografie, nun wird einer dieser optischen Schätze feilgeboten – in London, zum Preis einer Eigentumswohnung.

Lesezeit: 2 Min. In Pocket speichern

29

25.04.2012 00:01 Uhr | c't Fotografie

Von Peter Nonhoff

<https://www.heise.de/foto/meldung/Die-Linse-die-nach-hinten-schaut-1557410.html>

Sie lieben Weitwinkelaufnahmen und waren schon immer auf der Suche nach einem Fisheye mit extremem Öffnungswinkel – einem wirklich weiten Weitwinkel? Hier haben wir das richtige für Sie: Ein Nikkor 6mm f/2.8 Fisheye. Angeboten wird es gerade bei Gray's of Westminster in London für bescheidene 100.000 englische Pfund.

Diese Linse wurde das erste Mal 1970 auf der Photokina in Köln gezeigt, die Produktion startete zwei Jahre darauf im März 1972. Gefertigt wurde sie erst auf Anfrage des Kunden. Das Nikkor 6mm f/2.8 Fisheye ist die bislang extremste Weitwinkellinse, die für das 35-mm-Kleinbildformat gebaut wurde. Sie besitzt einen extremen Öffnungswinkel von



Nikkor 6mm f/2.8 Fisheye. Erst der Vergleich mit der angeflanschten Kamera verdeutlicht die beeindruckenden Dimensionen. (Bild: Tony Hurst)



ein *Fisheye*-Zoom

AF-S Fisheye NIKKOR 8-15mm f/3.5-4.5E ED

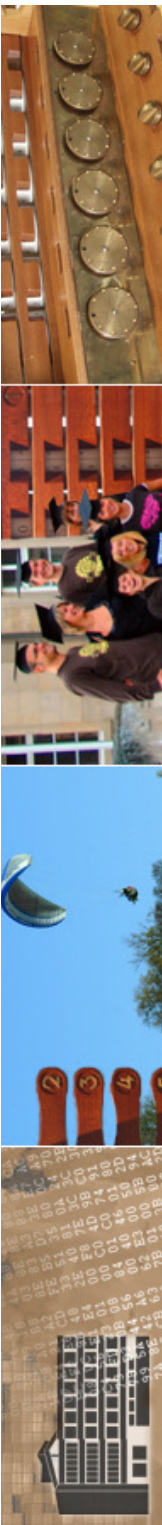



Tilt- & Shiftobjektive

- Verschieben (Shift) und Verschwenken (Tilt) des Linsensystems gegenüber Film oder Sensor
 - Shift: Korrektur der Perspektive
 - Tilt: Anpassen der Ebene der Schärfentiefe
- TS-Objektive benötigen einen (deutlich) größeren Bildkreis

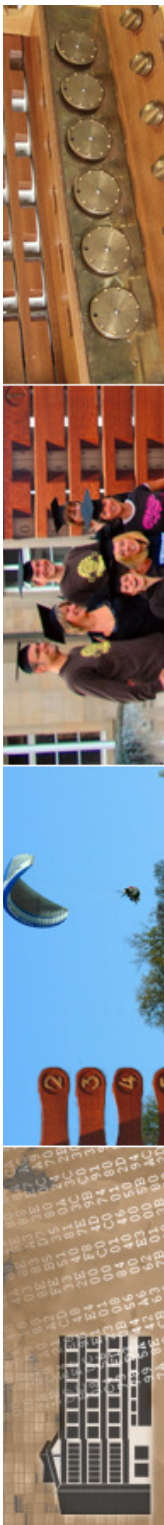

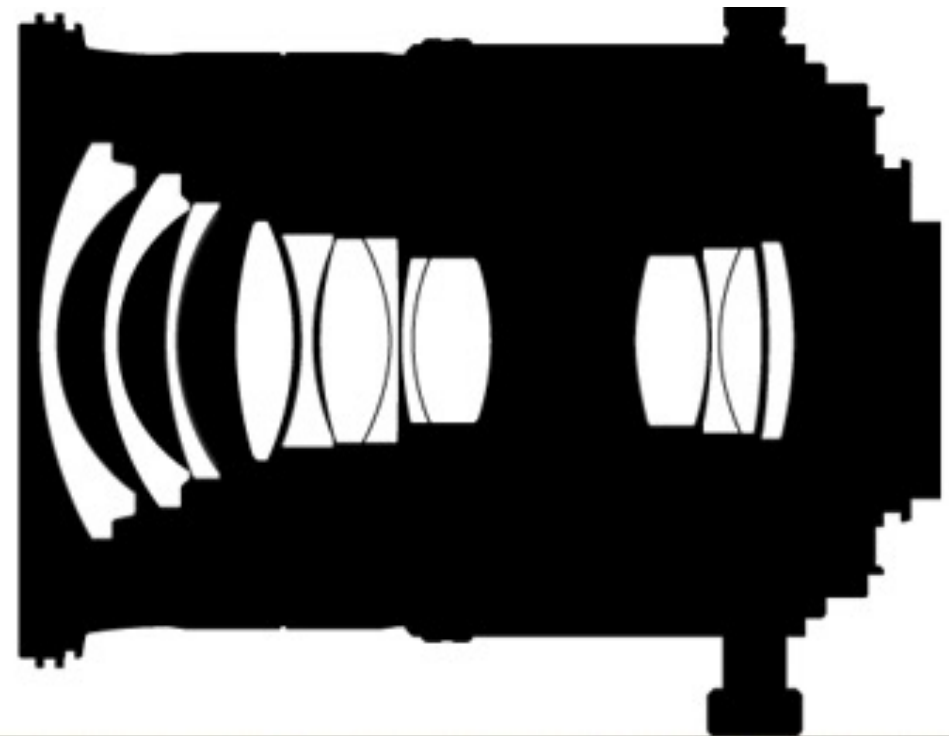
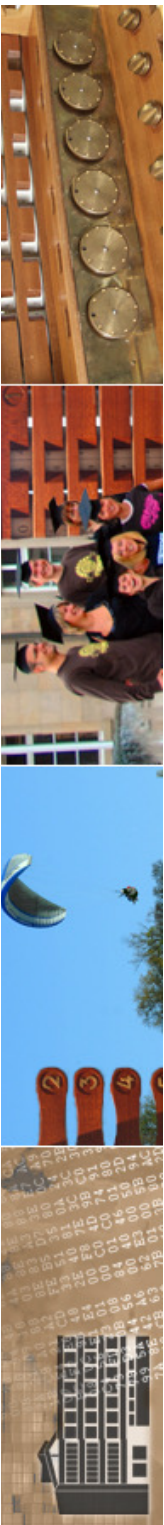

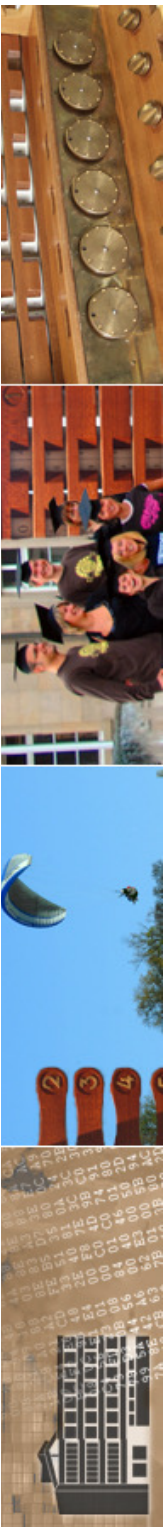

ein modernes Beispiel

— Linsenschnitt

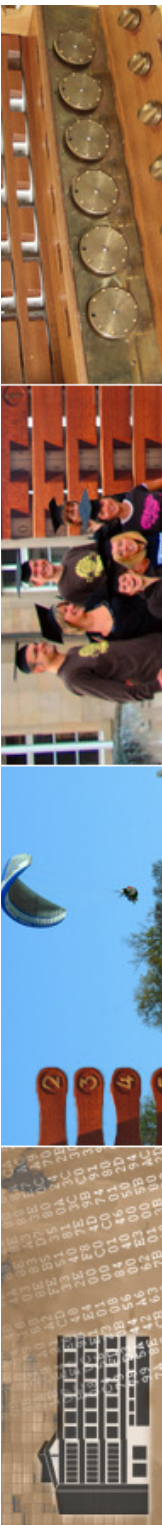
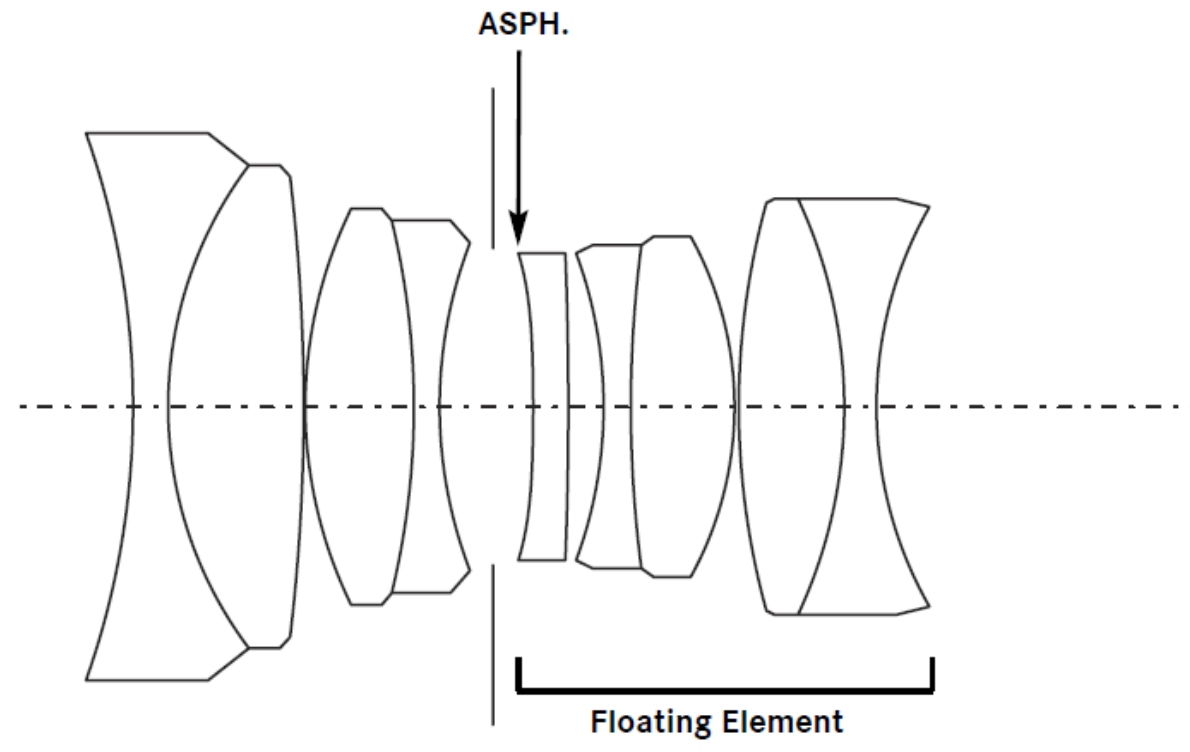



ein modernes Beispiel



TECHNISCHE ZEICHNUNG



LINSENSCHNITT



Abbildung 1:2



CSC APO Summicron SL vs. M Baugrößenvergleich



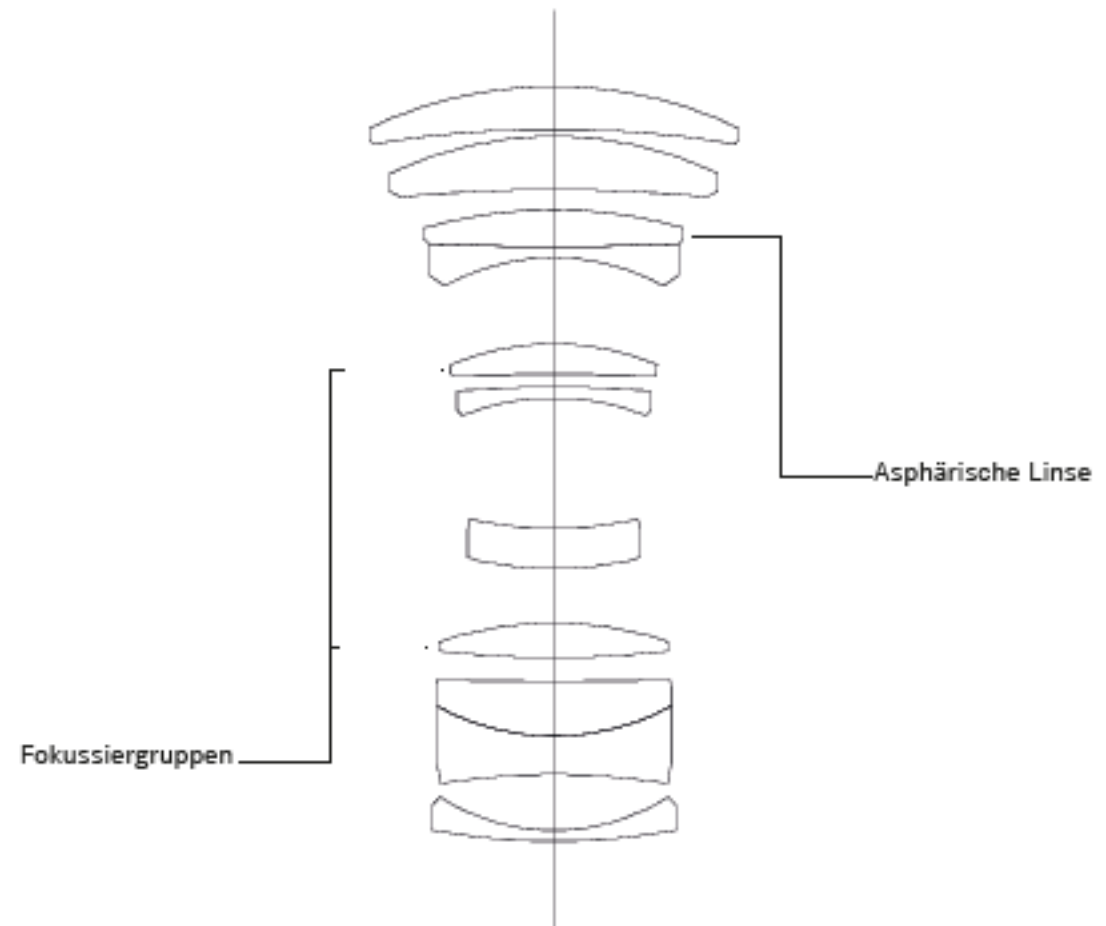
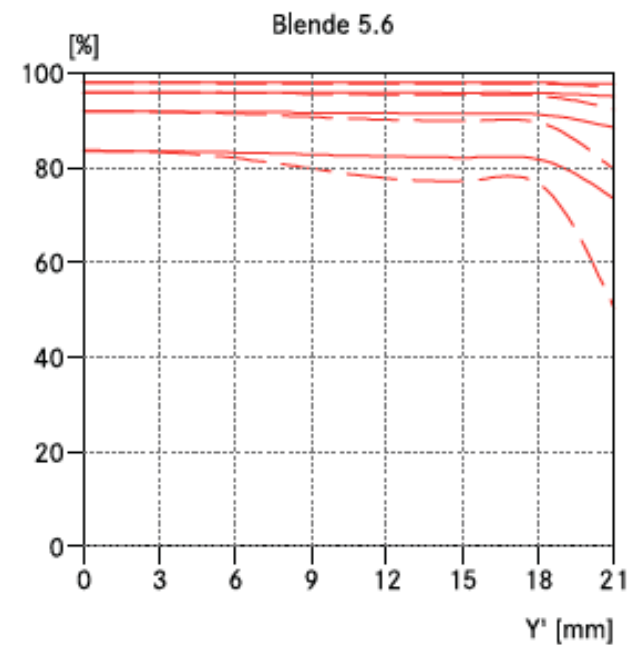
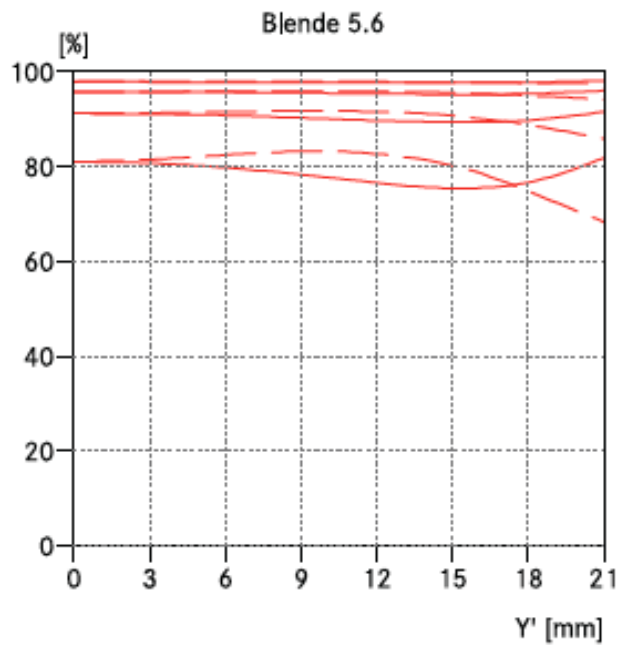
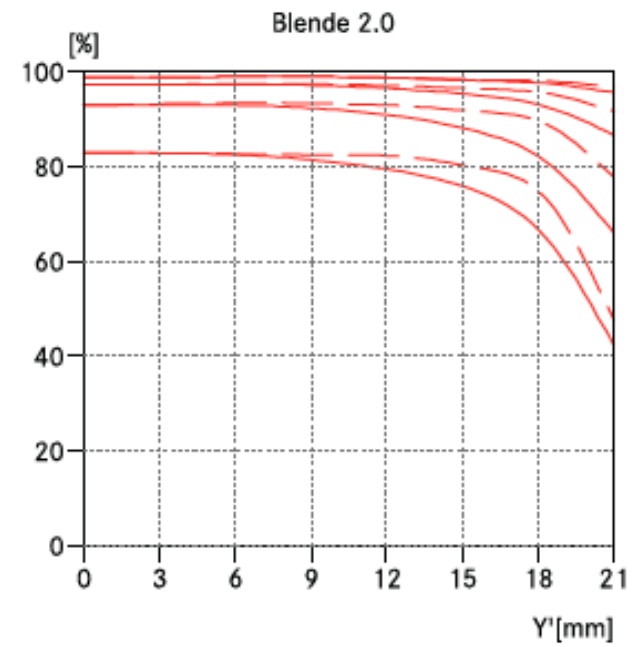
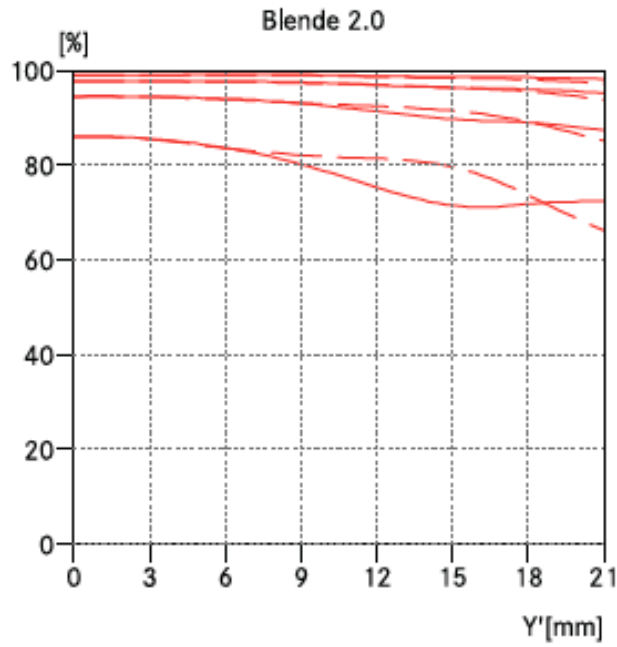
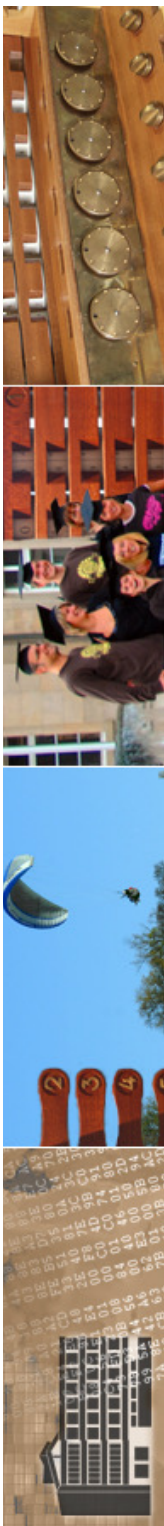
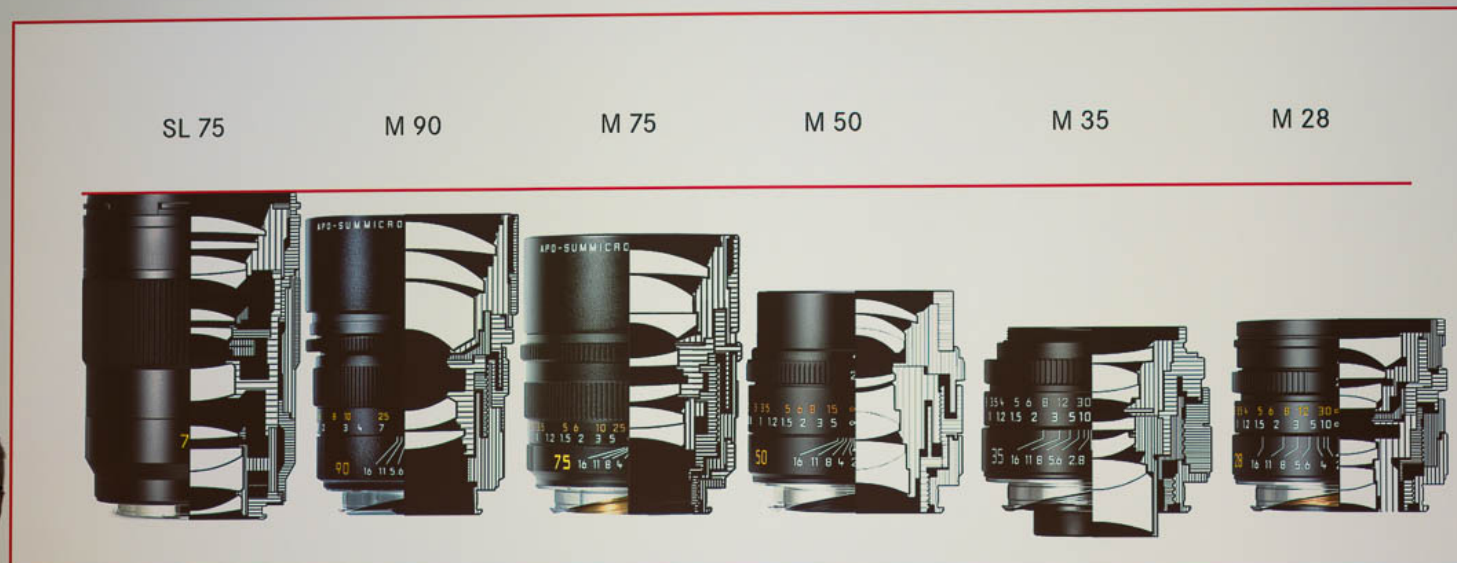

Auflösung und Pixelgröße

- je mehr Pixel → je kleinere Pixel
- je kleinere Pixel → je bessere MTF notwendig

| Kameramodell | Pixelgröße |
|----------------------|--------------------|
| Canon EOS 1D | 11,5 μm |
| Canon EOS 1Ds | 8,8 μm |
| Canon EOS 1D Mark II | 8,2 μm |
| Canon EOS 300D/10D | 7,4 μm |
| Nikon D100/D70 | 7 μm |
| Canon EOS 20D | 6,4 μm |
| Nikon D2X | 5,5 μm |

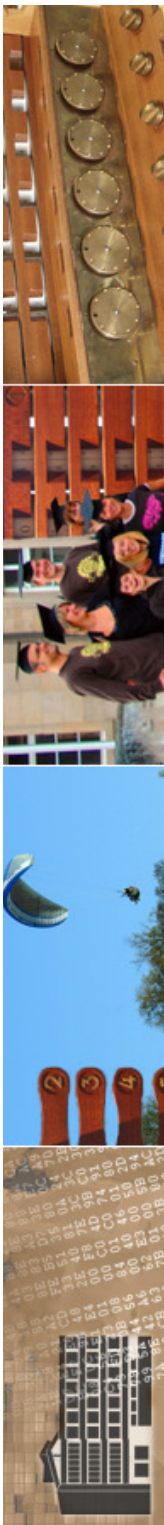

Randstrahlen

- Randstrahlen im Digitalen kritisch wegen Struktur des Sensors
– im Analogen egal

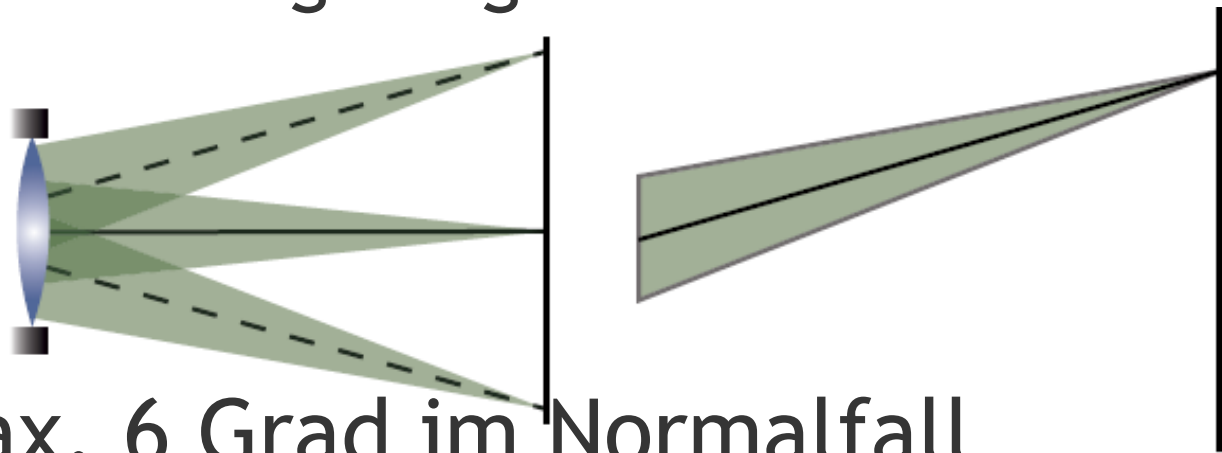

- max. 6 Grad im Normalfall
- sonst: IFP: italian flag phenomenon

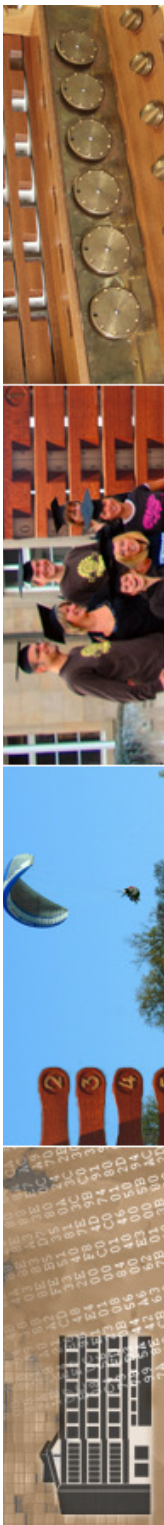

Randstrahlen

- spezielle Sensoren

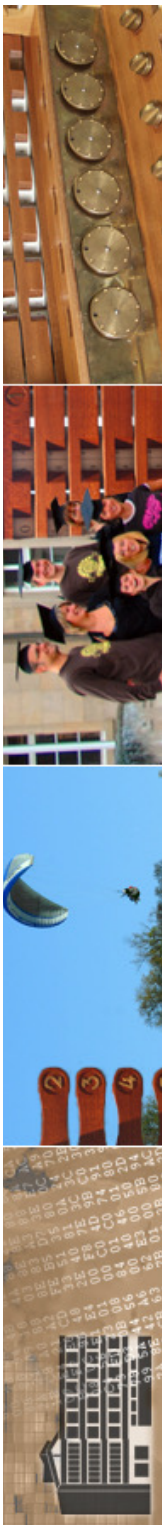
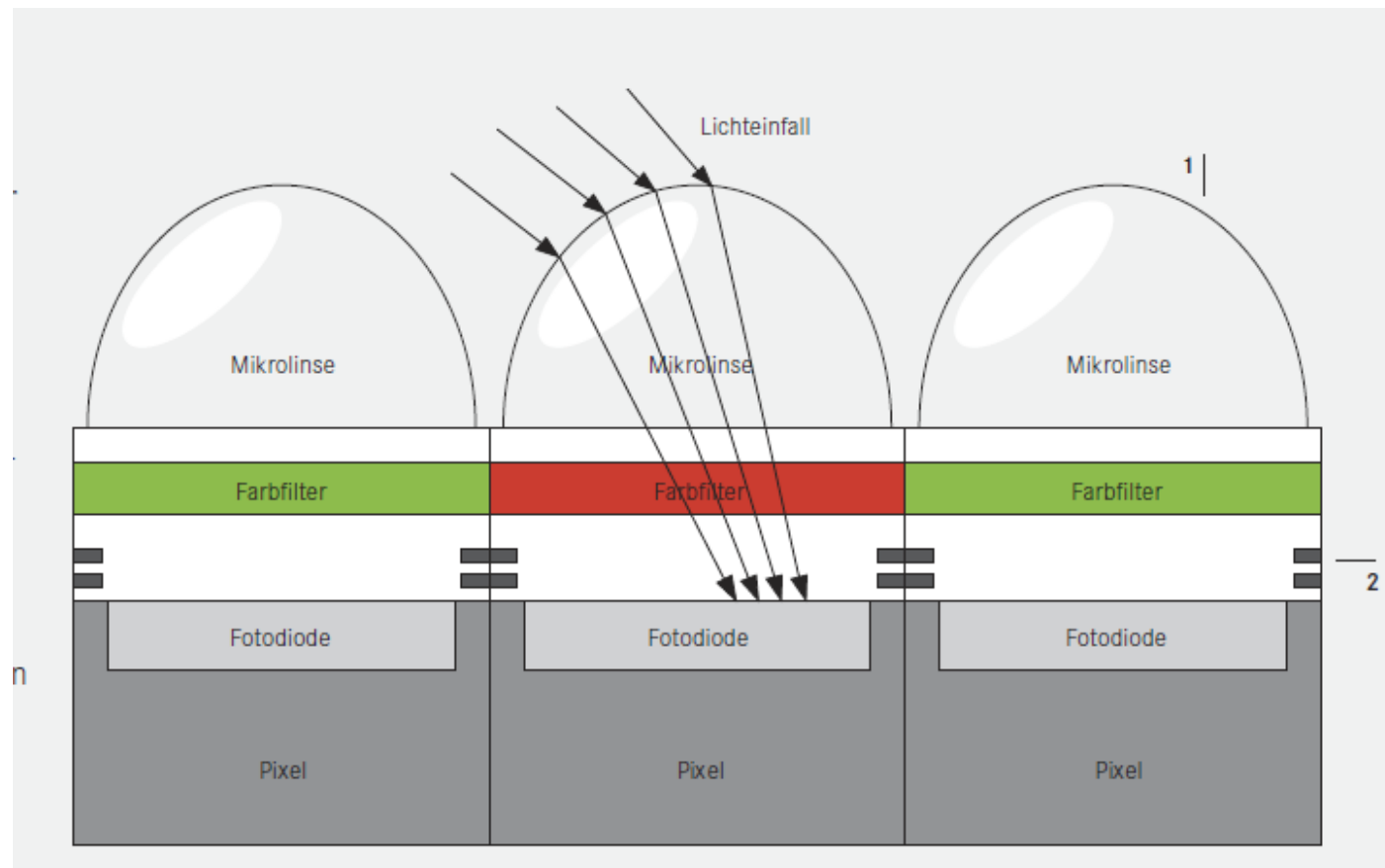

ein aktuelles Beispiel

- Leica APO-Summicron-SL 1:2/35mm asph.
 - 13 Linsen in 11 Gruppen
 - 750 g, 67mm Frontlinse
 - 5 asphärische Flächen an 3 Linsen



Unendlich (∞)

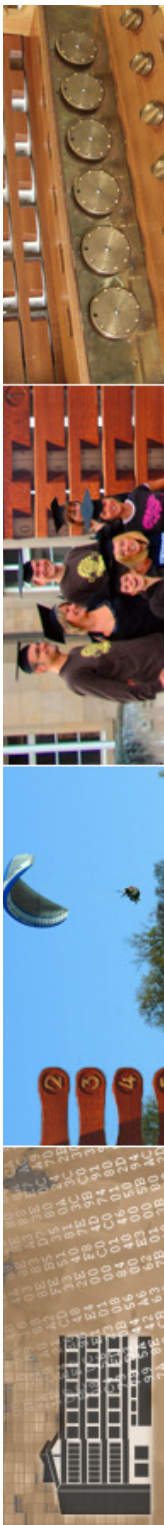
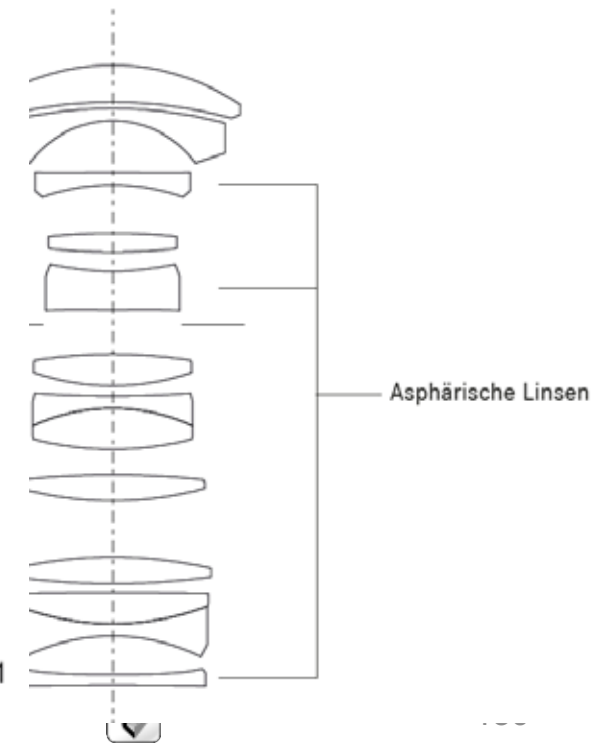
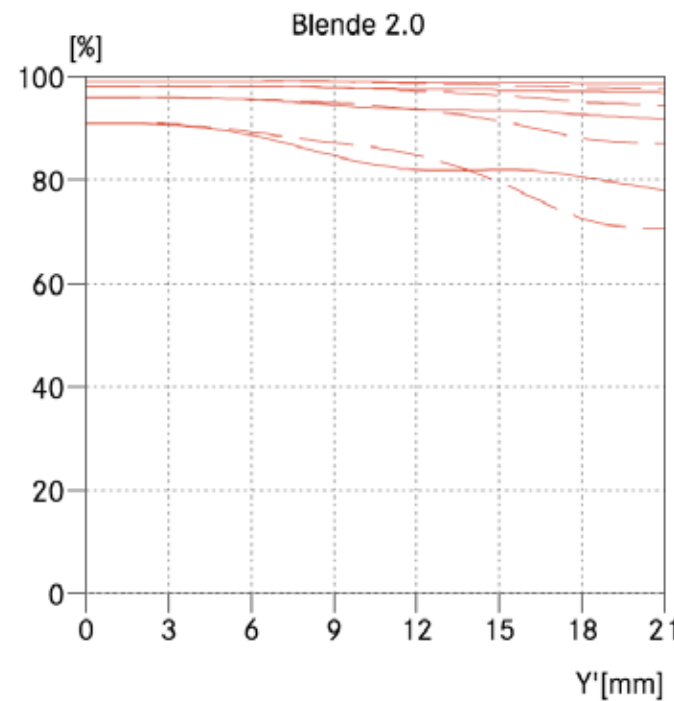

...und nun...

- kennen wir die physikalischen Grundlagen der Fotografie



- als nächstes:
etwas Chemie, Blitz, das Bajonett und der Begriff „Kontrast“ - und Ansel Adams

